



Medical Equipment Washer Operating Manual AQ-8000

Medical Equipment Washing & Decontamination Systems



Your Aqua Phase Includes the Following Options:

240 V 50 Hz

Digital Temp. Gauge

READ ALL MATERIAL PRIOR TO OPERATION

Aqua Phase, A Division Mid-State Stainless Inc. •330 W Benson Ave. •PO Box 228 •Grantsburg, WI 54840 •USA
800-208-9274 •715-463-5851•FAX: 715-463-5853• Email: aquaphase@medwashers.com •WEB: www.aqua-phase.com

Description	Page
Caution & Notices	Page 4
General Information	Pages 5-11
Basic Set-Up Procedures	Pages 12-13
Fill & Drain Line Information	Pages 14-16
Controller Information	Page 17
Operating Procedures & Wash Sequence	Page 18
Disinfectant Application System	Page 19
Daily Operations & Daily Operations Log	Pages 20-21
Periodic Operations & Periodic Operations Log	Pages 22-23
Aqua Phase Limited Warranty	Page 24
Control Panel Controls & Electrical Layout	Page 25
Fuses	Page 26
Wire Diagrams	Pages 27-29
Domestic Parts Listing	Pages 30-33
Disinfectant Pump	Page 34
Drain Pump—Shertech	Page 35
Drain Pump—AMT	Page 36
Typical Chemical Pump Assembly	Page 37
Valve Inspection Procedures	Page 38
Technical Data 1/2" Valve (Fill & Disinfect)	Page 39
Technical Data Disinfectant Mixing Valve	Page 40
Single-Stage Injector Models	Page 41
Pump Impeller Inspection Procedures	Page 42
Main System Pump	Page 43



Medical Equipment Washing & Decontamination Systems

Description	Page
AMT Drain Pump	Page 44
Shertech Drain Pump	Page 45
Troubleshooting Guide	Pages 46-53
Aqua Phase Chemicals & Descriptions	Page 54
AQ-240 Cleaning Solution SDS	Pages 55-60
AQ-260 Rinse Solution SDS	Pages 61-65
AQ-280 Rust Inhibitor SDS	Page 66-71
AQ-725 Deliming Solution SDS	Pages 72-77
Deliming Instructions	Pages 78-80
HDQ Neutral Disinfectant SDS	Pages 81-86
PD-128 Disinfectant SDS	Pages 87-93



CAUTION & NOTICES

Medical Equipment Washing & Decontamination Systems

- DO:** Read this operations manual and follow all instructions.
- DO:** Call your dealer, sales representative, or the factory with any questions, need for more information, or to order supplies for your *Aqua Phase Washer*.
- DO:** Wear Personal Protective Clothing
- DO NOT:** Operate the machine without all the filter screens in place.
- DO NOT:** Climb into the Wash Chamber.
- DO NOT:** Wash any item with unsealed electrical components. Unless IP 65 rated or higher.
- DO NOT:** Perform any type of service operation unless the machine is unplugged.
- DO NOT:** Use an extension cord between the wall outlet and the machine.
- DO NOT:** Try to modify the machine in any manner without factory approval.
- DO NOT:** Operate the machine in high foot traffic areas.
- DO NOT:** Use garden hoses for the fill and drain hoses.
- DO NOT:** Operate the machine unless you have been properly trained to run the machine.

Aqua Phase carries a complete line of supplies and parts and a variety of cleaning, rinse, and disinfectant solutions specifically formulated and chosen to work with your ***Aqua Phase*** machine. You may order your solutions, supplies, or parts by calling your dealer or ***Aqua Phase*** at 800-208-9274 or 715-463-5851.



GENERAL INFORMATION

Medical Equipment Washing & Decontamination Systems

FRONT VIEW

FRONT DOOR SAFETY SWITCH

CONTROL PANEL

CHEMICAL CABINET

MECHANICAL CABINET ACCESS PANEL

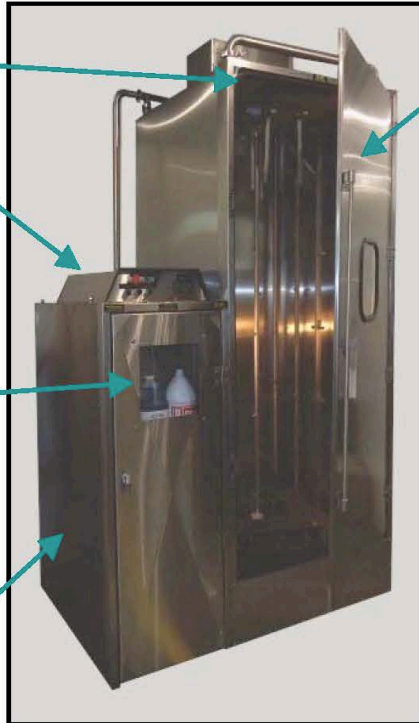

FRONT CHAMBER DOOR

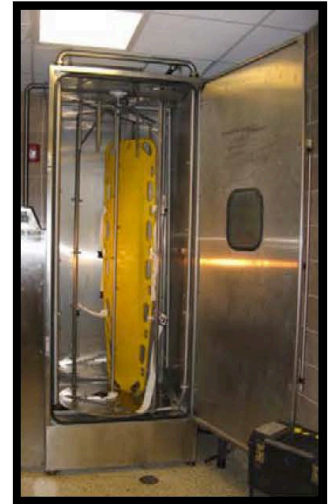

Showing Washer with a Backboard

TOP / REAR VIEW

EXTERIOR SPRAY ARM WATER SUPPLY PIPES

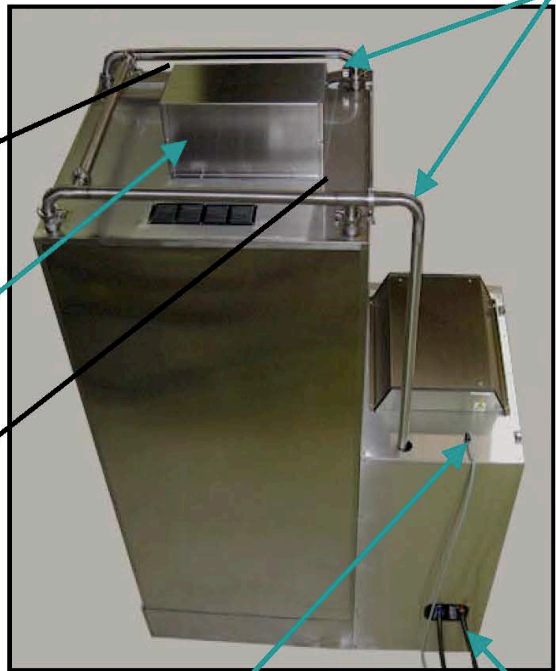

GEAR MOTOR FOR ROTARY CAROUSEL SYSTEM

ROTARY CAROUSEL CHAIN DELRIN

CAROUSEL GEAR MOTOR COVER

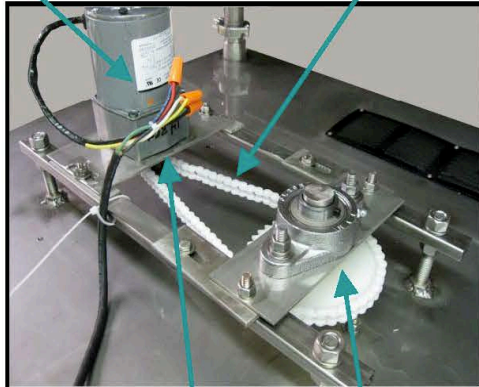

Inside Motor Case

GEAR MOTOR FORGED SPROCKET

LARGE DRIVE SPROCKET

ELECTRICAL CORD

FILL & DRAIN LINE CONNECTIONS



GENERAL INFORMATION

Medical Equipment Washing & Decontamination Systems

DISINFECTANT
CEILING ARM

BACKBOARD
SUPPORTS



Inside Wash Chamber – Ceiling View



Inside Wash Chamber – Ceiling View above Rotary Deck

CENTER SPRAY ARM & SHAFT

CENTER BEARING

DISINFECTANT SPRAY ARMS

For Disinfectant Application Cycle (qty two & ceiling)

STRAP
HANGERS

CORNER
SPRAY ARMS

For Wash & Rinse Cycles (qty four)

BACKBOARD
'V' HOLDERS

(Total Quantity of four)

ROTARY DECK

FRONT DOOR GASKET

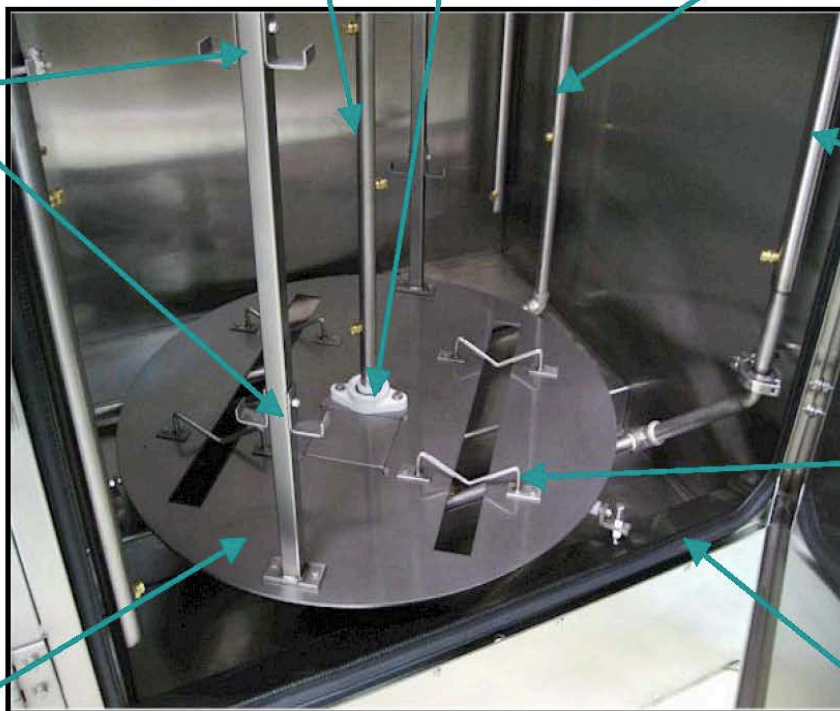

Inside Wash Chamber – Viewing the floor



GENERAL INFORMATION CONTROL PANEL SWITCHES & FUNCTIONS

Medical Equipment Washing & Decontamination Systems

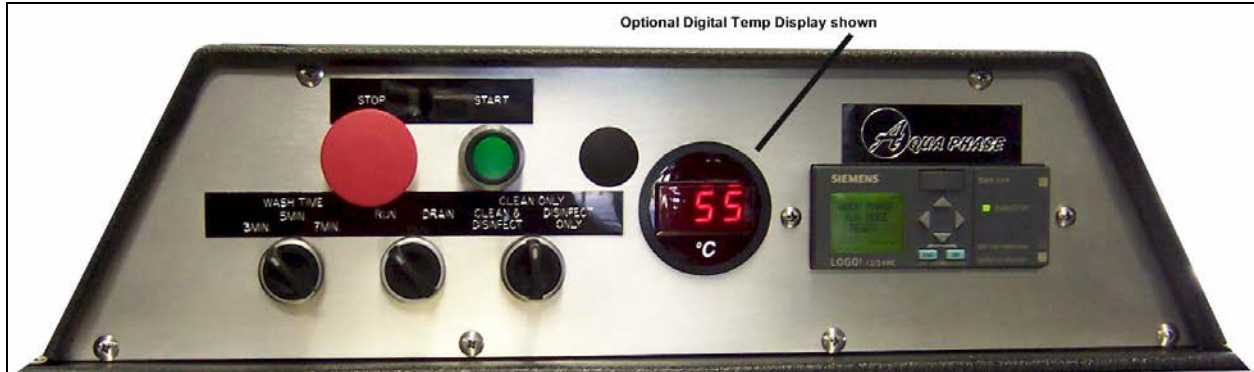

Switch	Options/Function
“STOP” Button	When pressed, will stop all Aqua Phase wash functions
“START” Button	Must be pressed to start any Aqua Phase wash function
WASH TIME Selector Switch	Allows you to select the length of wash: “3 MIN” = Three minute wash cycle “5 MIN” = Five minute wash cycle “7 MIN” = Seven minute wash cycle
“RUN/DRAIN” Selector Switch	<p>“RUN”: Set to “RUN” to wash an item.</p> <p>“DRAIN”: Set to “DRAIN” to drain the water in the machine. The water should be drained when you are done washing for the day or if you relocate the machine. In order for the “DRAIN” function to work, the Wash Mode switch must be set to “CLEAN & DISINFECT” or “CLEAN ONLY”.</p>
WASH MODE Selector Switch	<p>“CLEAN & DISINFECT”: When this mode is selected, <i>Aqua Phase</i> will perform a complete wash and rinse for the time specified on the WASH TIME Selector Switch. It will then automatically apply disinfectant solution.</p> <p>“CLEAN ONLY”: When this mode is selected, <i>Aqua Phase</i> will perform a complete wash and rinse cycle for the length of time specified on the WASH TIME Selector Switch. It will not apply disinfectant.</p> <p>“DISINFECT ONLY”: When this mode is selected, <i>Aqua Phase</i> will apply disinfectant solution only. It will not wash or rinse.</p>



GENERAL INFORMATION MECHANICAL COMPONENTS

Medical Equipment Washing & Decontamination Systems

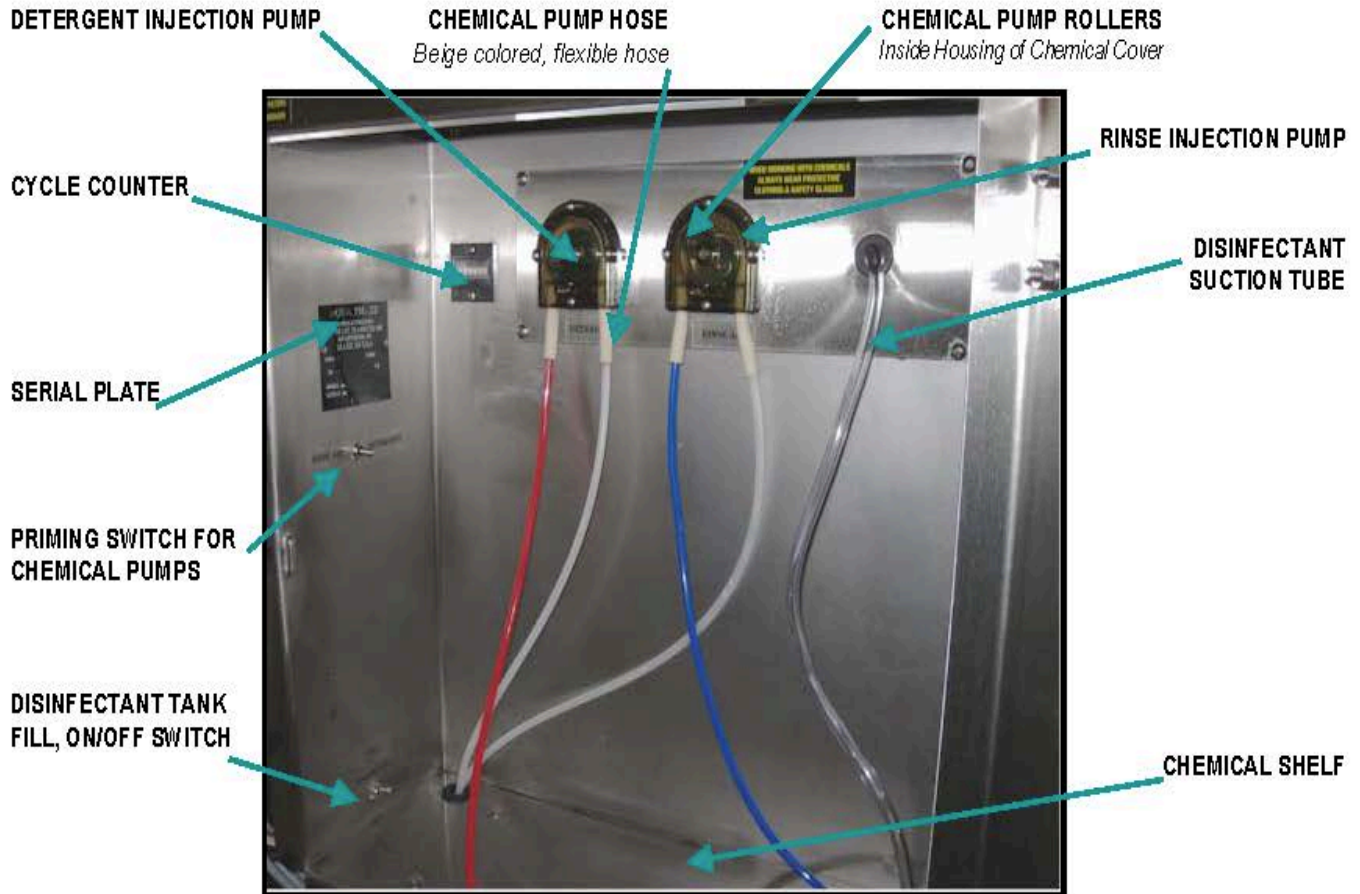

The chemicals that the Aqua Phase system uses will be placed in the Chemical Cabinet, on the Chemical Shelf.

- The AQ-240 Cleaning Solution gallon is placed on the left of the Chemical Tray with the yellow tube inserted into the gallon.
- The AQ-260 Rinse Solution (or AQ-280 Rust Inhibitor) gallon is placed in the center with the Blue tube inserted into the gallon.
- The Disinfectant Solution gallon is placed on the right of the Chemical Tray with the clear tube inserted into the gallon.

The Aqua Phase system automatically dilutes and applies the chemicals in the Wash Chamber.

- For the Detergent line, our AQ-240 Cleaning Solution is used. This chemical was specially formulated for the Aqua Phase systems.
- For the Rinse line, either the AQ-260 Rinse Solution or the AQ-280 Rust Inhibitor may be used.
- For the Disinfectant line, we offer two levels of disinfectant that are approved to use in the AQ systems. We do not formulate the disinfectant solutions. If your facility already has a brand of disinfectant, please contact Aqua Phase to see if it will work in the AQ system.

NOTE: Not all disinfectants are safe to use in the AQ system. Please contact Aqua Phase before using a different brand/type of disinfectant in your AQ system, other than the ones we offer. Warranty will be terminated if unapproved chemicals are used.



GENERAL INFORMATION MECHANICAL COMPONENTS (continued)

Medical Equipment Washing & Decontamination Systems

AQ-8000 Mechanical Cabinet- View with Mechanical Cabinet Access Panel removed

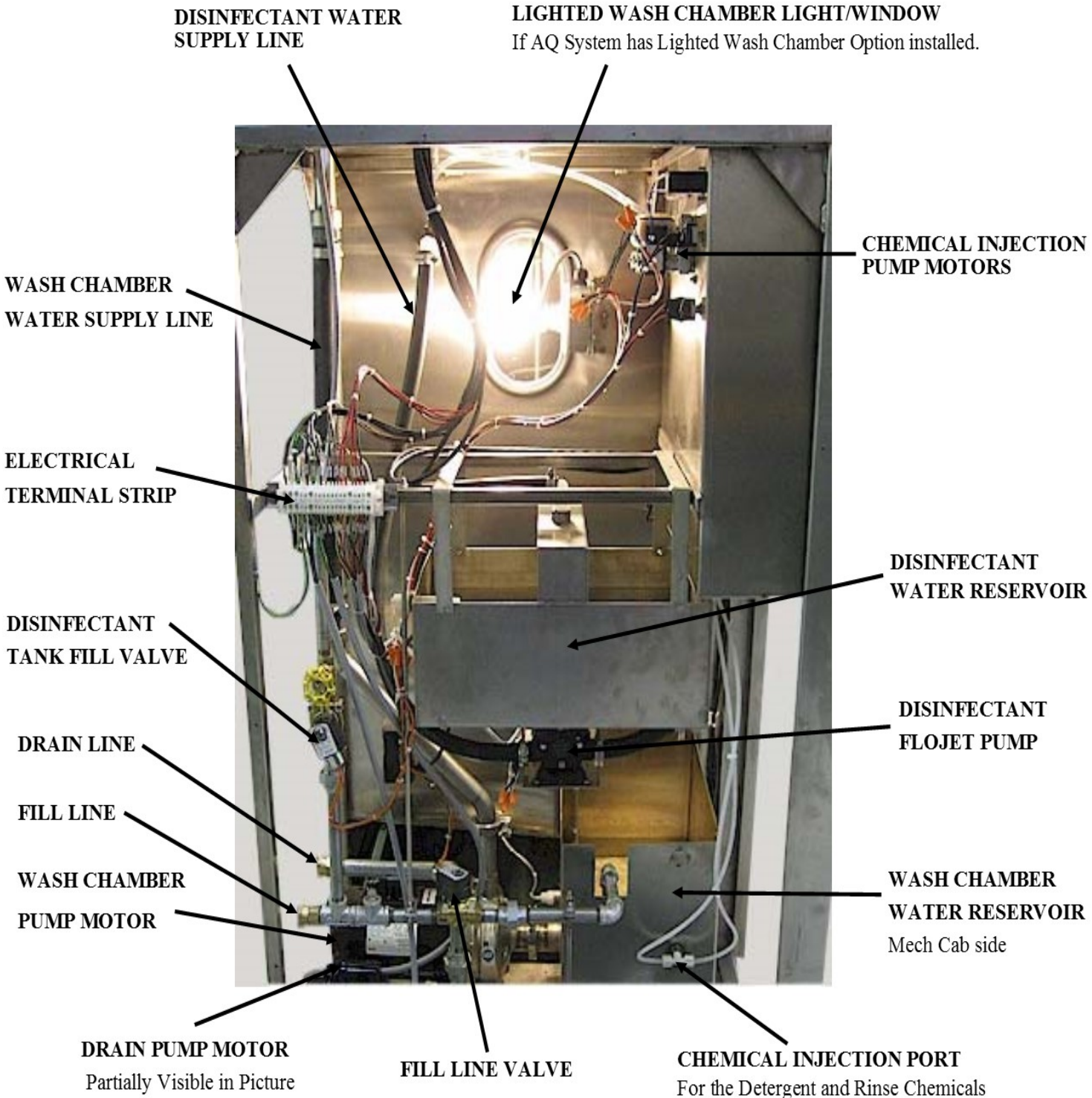



GENERAL INFORMATION FILTER SCREEN

Medical Equipment Washing & Decontamination Systems

IT IS RECOMMENDED THAT YOU CHECK THE FILTER DAILY FOR DEBRIS AND CLEAN THEM OFTEN.

WATER RESERVOIR SCREEN

Located in the Left/Front corner of the water reservoir tank.

If this becomes clogged and prevents water from getting to the pump, the Aqua Phase will make a "Growling" noise in addition to low pressure in the spray system.



Picture of Aqua Phase Wash Chamber *Looking through the Front Door*

THIS SCREEN MUST BE IN PLACE AT ALL TIMES OR PUMP DAMAGE MAY OCCUR.



Medical Equipment Washing & Decontamination Systems

GENERAL INFORMATION RECOMMENDATIONS

Recommendations:

Water Temperature: The Aqua Phase system will perform best when you supply hot water between 115-130°F (46-55°C). If the supplied water temperature is below 105° (40°C) water spotting or film may occur on the equipment:

Cleaning Solutions: It is highly recommended that you use Aqua Phase brand solutions for the gross soil removal, and rinse processes performed in the unit.

Disinfectants: Use a concentrate disinfectant with a 1 ounce per gallon dilution rate (1:128). Hydrogen Peroxide base disinfectants are NOT recommended as these substance are detrimental to Aluminum. Disinfectants with other dilution rates can be used, however, the dilution setting of the Aqua Phase unit will need to be modified (it is not difficult).

Plumbing-Hoses: Use hose for the Fill and Drain connections to the Aqua Phase unit verse ridged piping. This will make access to the Chemical Cabinet and Mechanical Cabinet much easier if service is needed, as well as for periodic cleaning of the floor under the Aqua Phase unit.

Requirements:

Electrical: Aqua Phase requires a 120 volt, 20 ampere electrical circuit. This should be a circuit dedicated for the use of the Aqua Phase unit.

Water Volume: Aqua Phase requires approximately 7.5 gallons of hot water per cycle. See "Aqua Phase Wash Sequence Description" for more details.

Water Pressure: Aqua Phase requires a minimum of 35 PSI (Pounds per Square Inch) (2.42 Bar) of water supply pressure.

Cleaning Solutions: The use of Aqua Phase brand solutions is a requirement in order for the Aqua Phase warranty to remain intact, unless the use of other solutions have been approved for use by the Aqua Phase factory. See the Warranty page for details.

Plumbing-Hoses: The discharge end of the Drain Hose must be at least 18" above floor level.



BASIC SET-UP PROCEDURES

Medical Equipment Washing & Decontamination Systems

If Aqua Phase has been transported during freezing weather, allow the Aqua Phase to warm for 4-6 hours before running.

1. Read all Aqua Phase instructions and operations material.
2. Remove Aqua Phase from the pallet.
3. Move Aqua Phase to location of operation. Ensure the Aqua Phase is level.
4. Remove items packed inside of the Wash Chamber for shipping (*optional racks, trays, chemical solutions, and hoses will often be packed inside the Wash Chamber*).
5. Connect the Fill Hose.
 - **DO NOT USE A GARDEN HOSE.** Only use hose rated for 150°F or more for both the fill and drain hose.
6. Connect the drain hose. The **drain end of the Drain hose MUST BE HIGHER than the drain hose connection on the washer**—see Fill and Drain Lines page for information. Drain hose must be securely fastened to the drain.
7. Once the fill and drain connections are secure, slowly turn on your hot water supply & inspected for loose connections.
8. For standard **120-volt operation**, connect Aqua Phase to a standard 20 AMP electrical service.
 - Press the reset button located on the GFCI (Ground Fault Circuit Interrupter). In the power cord.
 - **DO NOT** use a power extension cord between your wall outlet and Aqua Phase.
9. With special ordered **240-volt configuration**, the end user must make final connections and provide cord plug.
 6. Press the reset button located on the GFCI.

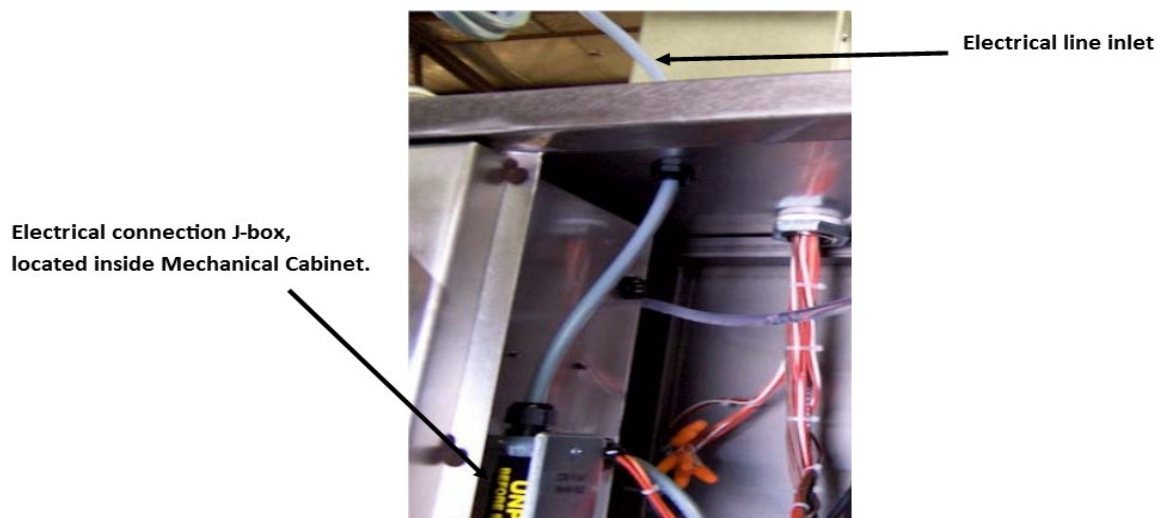

Due to the variety of receptacle and connection types and the variety of local codes and regulations, all electrical connections should be performed by a qualified electrician in accordance with local codes and regulations.

(continued on next page)



BASIC SET-UP PROCEDURES (Continued)

Medical Equipment Washing & Decontamination Systems

Warning:

Wear Protective Clothing When Working With Any Chemicals.

Warning:

Consult the material safety data sheets located in the back of this manual and your company's hazardous substance policy before handling any chemicals.

Key to *Aqua Phase* chemical solution hoses:

- The **YELLOW** hose is for detergent.
- The **BLUE** hose is for rinse-aid.
- The **CLEAR** hose is for disinfectant, if installed.



1. Place Chemical Solutions in the Chemical Tray (located inside the Chemical Cabinet at the rear of the Aqua Phase) as the locations marked "**DETERGENT**" and "**RINSE-AID**".
 - Remove chemical bottle caps and place the appropriate colored hoses in bottle openings **YELLOW** hose for Detergent/ **BLUE** hose for Rinse-Aid.
 - Do not dilute the Detergent or Rinse-Aid solutions.

NOTE: The disinfection injection rate is preset at the factory for use of a disinfectant that requires a dilution rate of 1 oz. per gallon of water. Contact the factory if adjustment of the injection rate is necessary.

3. On the control panel at the front of the machine:
 - Set the "**WASH TIME**" switch to "**3 MIN**".
 - Set the "**RUN/DRAIN**" switch to "**RUN**".
 - Set the wash mode switch to "**CLEAN & DISINFECT**" or "**CLEAN ONLY**" if no disinfectant application system is installed.
4. Close the front door.
5. Press the "**START**" button. The "**START**" button is located on the control panel at the front of the machine.
 - Allow *Aqua Phase* to run a two complete cycles before washing any items.

If *Aqua Phase* does not start, see the "**TROUBLESHOOTING: Will not start**" section of this manual or call the factory for support.



FILL & DRAIN INSTALLATION & NOTATIONS

Medical Equipment Washing & Decontamination Systems

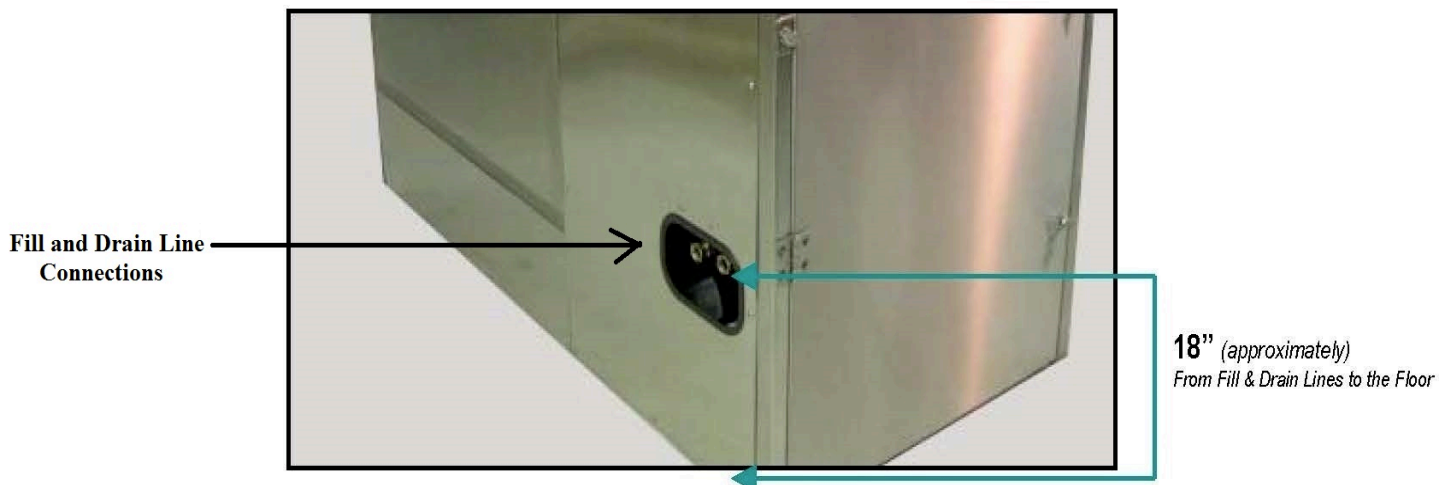

A SET OF TWO (2) 10' LONG HOT-WATER RATED HOSES ARE INCLUDED WITH YOUR *Aqua Phase* WASHER

- One (1) hose is for filling the washer (*fill line*), and is connected to your water supply.
- One (1) hose is for draining the washer (*drain line*)
- 25' long, hot water rated, hoses are available from Aqua Phase at an additional cost, if needed.

The *Aqua Phase* washer has female, garden hose style connectors for both the fill and drain line connections.

The overall design of the *Aqua Phase* washer creates a built-in fill line Air Gap.

However, this design may not be acceptable with your local building codes.

The *Aqua Phase* washer should be drained in accordance with local plumbing codes.

THE END OF THE DRAIN HOSE MUST BE HIGHER THAN THE DRAIN HOSE CONNECTIONS ON THE AQUA PHASE WASHER.

If the drain end of the Drain Hose is ran directly to a floor drain, water will siphon out of the Aqua Phase washer during operation.

Typically, the Drain Hose will run to a standpipe (*similar to the typical home washing machine setup*) or utility sink. It is recommended that a standpipe be used. Please check your local building codes for standpipe requirements. The standpipe should be a minimum diameter of 2" with a minimum height of 32". The drain hose must be secured at the drain to prevent a "whipping" action.



FILL LINE OPTIONS

Medical Equipment Washing & Decontamination Systems

5-27-17

AQUA PHASE: FACILITY WATER SUPPLY OPTIONS/METHODS: APPLICABLE FOR ALL MODELS. AQ-3000 MODEL SHOWN

DIRECTORY: CADKEY/PRT/AQ-UTILITIES
CAD FILE: AQ WATER SUPPLY OPTIONS.PRT
PDF FILE: AQ WATER SUPPLY OPTIONS

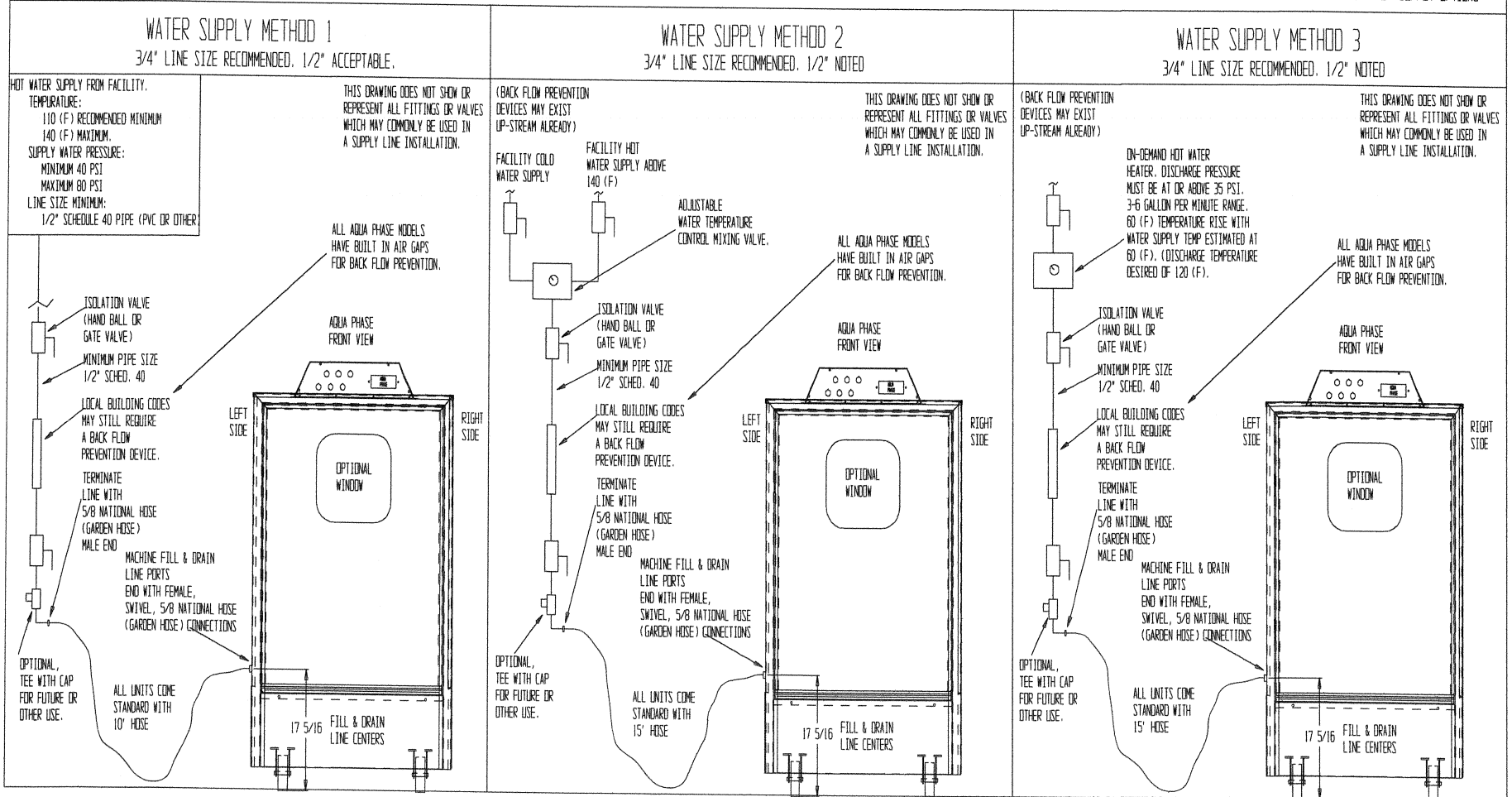



DRAIN LINE OPTIONS

Medical Equipment Washing & Decontamination Systems

5-27-17

AQUA PHASE: FACILITY DRAIN SYSTEM OPTIONS/METHODS: APPLICABLE FOR ALL MODELS. AG-3000 MODEL SHOWN

DIRECTORY: CADKEY/PRT/AD-UTILITIES
CAD FILE: AD-WATER SUPPLY OPTIONS.PRT
PDF FILE: AD-DRAIN SYSTEM OPTIONS

NOTES ABOUT AQUA PHASE DRAINING: ALL AQUA PHASE UNITS ARE A PUMP TO DRAIN SYSTEM. HOSE IS RECOMMENDED BETWEEN THE AQUA PHASE MACHINE AND THE RIGID DRAIN PIPING SYSTEM. THE DRAIN PUMP IS A CENTRIFUGAL, OPEN IMPELLER, TYPE. THE DRAIN DISCHARGE PRESSURE AT THE MACHINE IS 20-25 PSI. DRAIN HOSE ENDS MUST BE SECURED AS HOSE END MAY "WHIP" IF NOT SECURED. DRAIN RATE IS 3.5-7 GALLON PER MINUTE PENDING THE DRAIN LINE SIZE AND DISTANCE TO THE FINAL DRAIN LOCATION. 3/4" PIPE, SCHEDULE 40, PVC OR OTHER IS RECOMMENDED. AQUA PHASE IS STILL FUNCTIONAL WITH 1/2" BUT THE TIME TO DRAIN INCREASES.

CHECK LOCAL CODES FOR APPROVAL AND ACCEPTABILITY.

DRAIN OPTION/METHOD 1

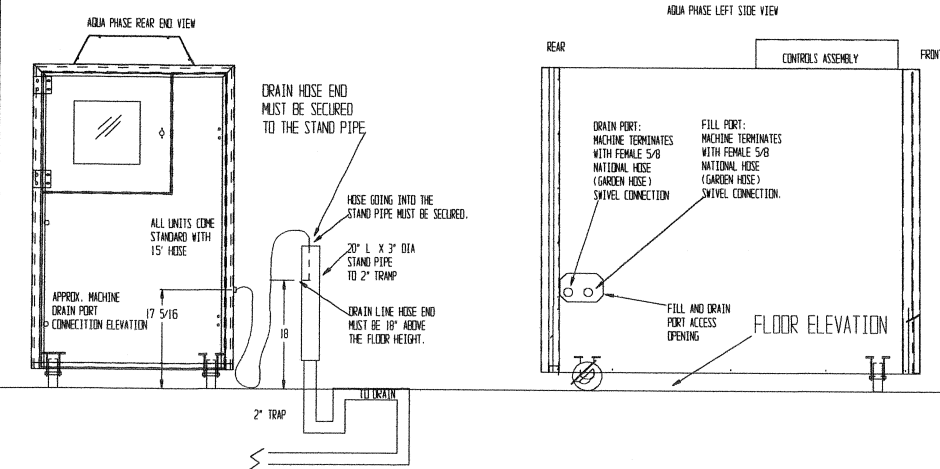

CHECK LOCAL CODES FOR APPROVAL AND ACCEPTABILITY.

DRAIN OPTION/METHOD 2

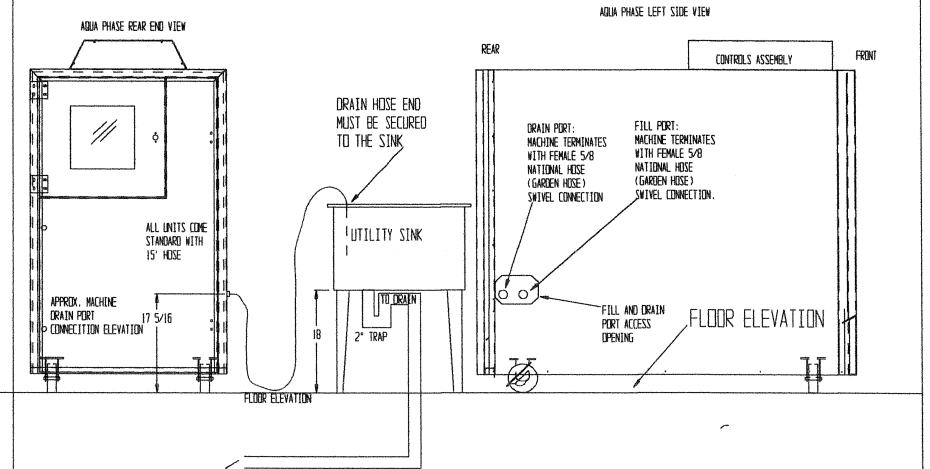

CHECK LOCAL CODES FOR APPROVAL AND ACCEPTABILITY.

DRAIN OPTION/METHOD 3

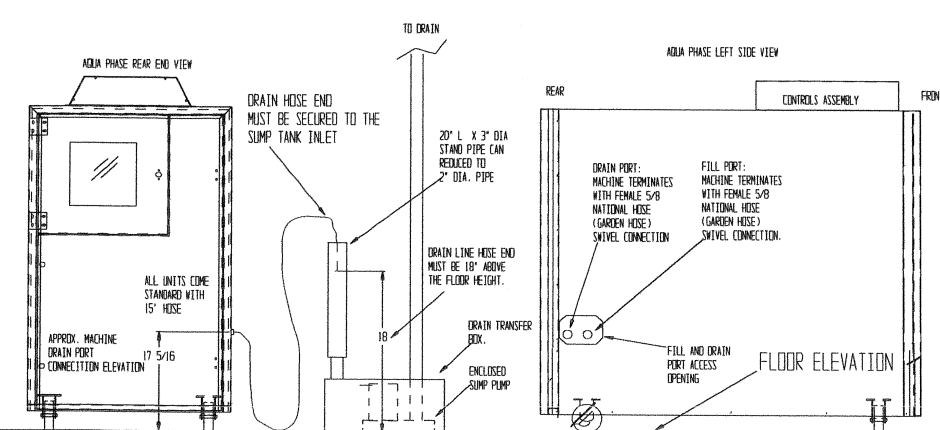

CHECK LOCAL CODES FOR APPROVAL AND ACCEPTABILITY.

DRAIN OPTION/METHOD 4

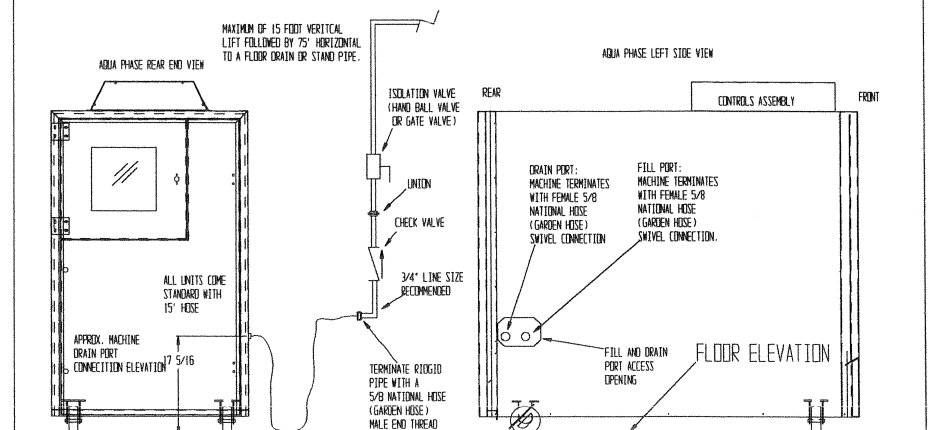



CONTROLLER INFORMATION



Message One

```

A Q U A   P H A S E
R U N   M O D E
Ready
  
```

Run mode selected.

- Doors closed.
- Ready to start.

Message Two

```

A Q U A   P H A S E
D R A I N   M O D E
Ready
  
```

Drain mode selected.

- Doors closed.
- Ready to start.

Message Three

```

A Q U A   P H A S E
W A S H   C Y C L E
Filling
  
```

Machine is filling for wash cycle.

- Run mode selected.
- Doors closed.
- "Start" button pushed.

Message Four

```

A Q U A   P H A S E
W A S H   C Y C L E
In Progress
  
```

Machine is in Wash Cycle.

- Machine done filling for wash cycle.
- Detergent solution automatically injected.
- Wash cycle will be for length of time selected (3,5, or 7 min)

Message Five

```

A Q U A   P H A S E
D r a i n
In Progress
  
```

Machine is done with wash cycle.

- Wash water is being drained. **OR**
- Drain mode selected and "Start" button pushed.

Message Six

```

A Q U A   P H A S E
R I N S E   C Y C L E
Filling
  
```

Machine is beginning Rinse cycle.

- Wash cycle complete
 - Wash water drained.
- Machine is filling with fresh water for Rinse cycle.

Message Seven

```

A Q U A   P H A S E
R I N S E   C Y C L E
In Progress
  
```

Machine is in rinse cycle.

- Machine done filling for rinse cycle.
- Rinse solution automatically injected. Rinse cycle will be for approximately 1.5 minutes.

Message Eight

```

D I S I N F E C T A N T
A P P L I C A T I O N
In - Progress
  
```

Disinfectant Application System Running

- Fresh water being mixed with disinfectant solution.
 - Item in Wash Chamber being sprayed with solution.
- "Clean & Disinfect" Selected before wash cycle started.
 - "Disinfect Only" selected & "Start" button pushed.
- Wash & Rinse cycle done.**

Message Nine

```

A Q U A   P H A S E
C y c l e
Complete
Open Door
  
```

Machine has completed selected operation.

Front door of Wash Chamber must be opened before next operation can begin.

- Item removed/loaded.
- Wash Chamber inspected for debris.
- Safety switches operational.

Message Ten

```

W A S H   S T O P P E D
* * * * *
C h e c k   L o w
L e v e l   S e n s o r
  
```

After Wash Cycle, prior to start of the draining of wash water.

Check low level float.

- Check that the low-level float is free of debris.
- Check if low level float is operating properly.

Call technical support if this does not solve problem



OPERATING PROCEDURES & WASH SEQUENCE

Medical Equipment Washing & Decontamination Systems

1. **Load the backboard(s) and or Straps**
2. **Make sure there are no straps or components that our outside the Perimeter (rotary deck) of the Carousel Deck.**
3. **Select the "WASH TIME"** (3, 5, or 7 minutes) on the Control Panel if your Aqua Phase is equipped with variable wash times. Choose the length of wash time based on the condition of the item to be washed.
4. **Set the "RUN/DRAIN" switch** on the control panel to "Run".
5. **Select the wash mode** ("Clean & Disinfect", "Clean Only," or "Disinfect Only") on the Control Panel if your Aqua Phase is equipped with the Disinfectant Application System.
6. **Push the "START" button** on the control panel.

Aqua Phase Wash Sequence Description

1. The current status of the wash sequence ("*Wash cycle*", "*Rinse Cycle*", "*Cycle complete*," etc.) will be on the LCD display of the Control Panel.
2. After pressing the "START" button, the computer will check to see if there is water in the Water Reservoir. If the reservoir is not full of water, Aqua Phase will automatically fill to the appropriate level. The reservoir holds approximately 7.5 gallons.
3. When the reservoir is full, the pump will start and begin the wash cycle spraying the item being washed. Detergent is automatically injected shortly after the wash cycle begins.
4. The Aqua Phase will now be in the wash phase and will continue for the wash time selected. *Either three, five, or seven minutes, depending the time you have selected for the 'Wash Time'*
5. When the wash phase is complete, the dirty wash water will be pumped out of the Aqua Phase to the drain.
6. Aqua Phase will automatically refill to the appropriate level with fresh water.
7. After the reservoir is filled with water, the pump will start and the Aqua Phase will begin its final rinse phase. The rinse agent is automatically injected shortly after the rinse phase begins. The rinse cycle will last for approximately 90 seconds.
8. The disinfectant application cycle will begin if selected and if installed on your Aqua Phase.
9. Pending the water level in the Reservoir in the Aqua Phase may automatically start Draining to prevent the unit from over flowing.

During normal automatic operation, the rinse water remains in the Aqua Phase and will be the wash water for the next item placed in the chamber. If you choose, you may drain the rinse water prior to beginning the next wash cycle.

TO DRAIN THE MACHINE MANUALLY

- Set the "RUN/DRAIN" switch to "DRAIN".
- Push the "START" button. The machine will drain the water.
- Prior to beginning the next wash cycle, set the "RUN/DRAIN" switch to "RUN".
- When the next wash cycle begins, the machine will automatically fill with fresh water for the wash phase.



Medical Equipment Washing & Decontamination Systems

DISINFECTANT APPLICATION SYSTEM

Follow all instructions provided by the manufacturer of the disinfectant solution that you choose to use including dwell time, application, removal, and proper handling of the disinfectant.

If Aqua Phase AQ-8000 has the Disinfectant Application System feature installed. The Disinfectant Application System allows you to automatically apply a disinfectant solution. The disinfectant solution that you choose to use with the Aqua Phase Disinfectant Application System, and the proper use of that disinfectant solution is responsible for the level of disinfection results that you achieve.

Disinfectant Solution:

- The Disinfectant Application System is preset at the factory to apply disinfectant at the rate of 1 ounces per gallon of water.
- Your Aqua Phase uses 162 to 172 ounces of water per disinfectant cycle.
- Your Aqua Phase will use/need 1.3 oz of disinfectant concentrate per cycle.
- Aqua Phase can provide disinfectant solutions specifically formulated or chosen to work with your Aqua Phase. You may order your solutions by calling your dealer or Aqua Phase at 800-208-9274.

Disinfection Application System Operating Instructions:

- Be sure that you are using a 1-ounce per gallon disinfectant. If not, see the notes below.
- Place a one (1) gallon container of your disinfectant solution in the Chemical Tray (located inside the Chemical Cabinet at the rear of the Aqua Phase).
 - Insert the **CLEAR** hose into the disinfectant container.
 - Close the Chemical Cabinet door.
- At the front of the Aqua Phase, select the desired WASH MODE (“Clean Only”, “Clean and Disinfect”, or “Disinfect Only”).

Note:

- If you choose to use a disinfectant that calls for a different dilution rate, Aqua Phase can be modified to accommodate that rate. For information on how to accomplish this modification, please call the factory for assistance or review the “Dema” technical information included with this manual.



DAILY OPERATIONS PROCEDURES

Medical Equipment Washing & Decontamination Systems

Start-up Procedures:

1. Check that the Aqua Phase Washer is connected to a water supply and that the water supply is turned on. Then confirm the Aqua Phase Fill and Drain Hose Connections are properly connected and secure.
2. Check the Primary Filter Screen inside of the Aqua Phase Reservoir to make sure you have a clean Primary Filter Screen. Make sure that the screen is put back in place properly.
3. Check the chemical supply levels, by looking in the Chemical Cabinet – located in the back, or side, of your Aqua Phase Washer.
4. Plug in the Aqua Phase and press the 'Reset' button located on the GFCI plug.

Operating Procedures

1. Load the item to be washed into the Wash Chamber, then close and latch the front door.
2. Set the 'Wash Time' (3, 5, or 7 minutes) selector switch, located on the Control Panel, to the desired wash time.
3. Set the '**Run/Drain**' selector switch to '**Run**'.
4. Select the Wash Mode Only if your Aqua Phase Washer is equipped with the Disinfectant Application System feature.
5. Push the green '**Start**' button located on the Control Panel. Aqua Phase Washer will now fill with water & begin the cycle selected.
6. When cycle is complete, open door of washer.
***Caution when opening the door-steam will come out of the door. The door and the item washed may be hot to the touch right away.*
7. Take the items out of the washer. On drying mat, tip the wheelchair on its handles to let the water on the seat run off.
8. Push the red 'Stop' button at any time during the cycles if problems arise.

Optional Step: Lay out a drying mat on the floor, by the Aqua Phase Washer Door, to soak up water when you remove items from the washer.

Shut-Down Procedures:

1. When you are finished for the day, set the '**Run/Dry**' selector switch to '**Drain**'.
2. Press the green '**Start**' button to completely drain the water out of the washer. Door has to be closed.
3. Open the door and clean the debris from the Primary Filter Screen – located just inside on the bottom of the Wash Chamber. Make sure the Filter Screen is put back in place properly.
4. Wipe clean the High Water Level Control (located inside, on the bottom of the Washer Chamber) clean.
5. Wipe the Low Water Level Control (located inside, on the bottom of the Wash Chamber) clean.
6. Turn off the water supply to the Aqua Phase Washer.
7. Un-plug the Aqua Phase Washer from the wall/power supply.
8. Open the front door of the Aqua Phase Washer if it will be a couple of days before next use.



DAILY OPERATIONS LOG

Medical Equipment Washing & Decontamination Systems

	DATE													
DAILY START-UP:														
Water Supply On														
Fill & Drain Hoses Secure														
Primary Filter Screen Clean														
Primary Filter Screen in Place														
Wipe Reservoir Area Floor Clean														
AQ-240 Cleaning Solution Level														
AQ-260 Rinse Solution Level														
Disinfectant Solution Level														
GFCI is Set														
"READY" message Displayed														
DAILY SHUT DOWN:														
Aqua Phase Unit Drained														
Primary Filter Screen Clean														
Primary Filter Screen in Place														
Wipe Reservoir Area Floor Clean														
High Level Control is Clean														
Low Level Control is Clean														
Run "Disinfectant Only" Cycle														
Check AQ-240 Cleaning Solution Level														
Check AQ-260 Rinse Solution Level														
Check Disinfectant Solution Level														
WEEKLY:														
Primary Filter Screen Clean														
Wipe Reservoir Floor Clean														
Wipe High Water Level Control														
Wipe Low Water Level Control														
Check AQ-240 Cleaning Solution Level														
Check AQ-260 Rinse Solution Level														
Check Disinfectant Solution Level														
Cycle Counter Reading														



WEEKLY, MONTHLY & ANNUAL OPERATING PROCEDURES

Medical Equipment Washing & Decontamination Systems

Weekly (or as needed):

1. Inspect the front door gasket for wear or damage. Replace if necessary.
2. Check the Spray Nozzles & Level Sensors (located inside the Wash Chamber) for clogging. Clean if necessary.
3. Check that the Drain through Hinged Reservoir Screen is clean & in place. Located at the bottom, inside the Wash Chamber.
4. Check the Power Cord for any wear or damage. Test and reset the GFCI in the Aqua Phase Power Cord. *(If the Power Cord appears to be damaged in any way, do not operate the Aqua Phase.)*
5. Use delimiting agent to reduce scale build-up if needed. Contact Aqua Phase to order **AQ-725 Delimiting Solution**.

Monthly:

WARNING- *Wear Personal Protective Gear/Clothing when working with ANY chemicals.*

1. Perform the delimiting process using the Aqua Phase, **AQ-725 Delimiting Solution**. The instructions are in the Aqua Phase manual, and printed on the AQ-725 Delimiting Solution bottle.
2. If included in the water supply line to your Aqua Phase, change the Filter Element that is inside the Water Filter Housing.
3. For Infection Control reasons, if possible change/switch the manufacture, brand, or type of concentrated disinfectant that you are using to Aqua Phase every 30-days.

Semi-Annual:

WARNING- *Wear Personal Protective Gear/ Clothing when working with ANY chemicals.*

1. Confirm the Disinfectant Concentrate Solution suction rate. *(This should be ¾ to 1 ounce of Disinfectant Concentrate Solution suctioned into the Aqua Phase per 'Disinfectant Only' cycle performed.)*
2. Inspect, check and adjust the Drive Chains of the wheelchair, Wheel Rotation System.
3. Inspect, check and change (as needed) the Wheel Cleaning Brushes of the Wheel Rotation System.
4. Inspect and replace if needed, the Primary Filter Screen.
5. Inspect and adjust the tension of the chain running from the driver motor on top of the Aqua Phase unit. *Contact the factory if you have any questions.*
6. Inspect the Front Door Gasket for wear or damage. Replace if necessary.

Annual:

Complete the Annual Aqua Phase Re-Validation Check Report. (The Check List/Report is available from Aqua Phase upon request). The Re-Validation is completed for you as part of an Aqua Phase Service Agreement.



Medical Equipment Washing & Decontamination Systems

DATE: _____

PERIODIC OPERATIONS LOG

	DATE												
MONTHLY:													
Test Ground Fault Circuit Interrupter													
Inspect Door Gasket													
Inspect Spray Nozzels for Cloggs													
Run Deliming Process													
6-MONTH INTERVAL													
Inspect Chamber Disinfectant Nozzle Spray													
Inspect / Adjust Drive System Chains													
Inspect Spray Arm Timing													
Validate Disinfectant Consumption (1.3 oz)													
12-MONTH INTERVAL													
Replace Detergent Pump Hose													
Replace Rinse Pump Hose													
Inspect Pressure Regulator													



AQUA PHASE MEDICAL EQUIPMENT WASHER LIMITED WARRANTY

Medical Equipment Washing & Decontamination Systems

Aqua Phase washers are warranted by Mid-State Stainless, Inc. (MSSI) to the original user against defects and workmanship or material under normal use:

- (a) for one year on component parts.
- (b) for five years on the stainless steel wash chamber.
- (c) 90-days on labor for any of the above.

This limited warranty ensues on the day of purchase.

This warranty is valid only if Aqua Phase AQ-240 detergent and AQ-260 rinse-aid are used in the Aqua Phase washer. The use of cleaning and rinse agents other than those listed above without express written consent from Aqua Phase/Mid-State Stainless, Inc. shall void this warranty immediately.

If the Buyer notifies Mid-State of a warranty claim during the appropriate warranty period and the Buyer affords Mid-State a reasonable opportunity to inspect the product, and if the product is in fact found to be defective by reason of latent or inherent defect in material or workmanship and returned to an authorized service location, as Mid-State designates, shipping costs prepaid, then Mid-State will, at Mid-State's election, either repair such product or replace the product F.O.B. Factory. No product shall be returned without Mid-State's prior consent in writing.

Limitation of Liability: Disclaimer of Implied Warranties. The Buyer's sole and exclusive remedy on account of the furnishing of products or services by Mid-State shall be to secure the repair or replacement of the defective products from Mid-State on the terms and subject to the conditions specified above. Mid-State shall have no responsibility for any failure of the products or of related equipment or any loss, damage or injury resulting from: (a) the improper design, manufacture, maintenance or operation of any equipment into which the products are incorporated or in connection with which the products are used; or (b) the use of the products for other than their intended purpose; or use or operation outside the specified environmental conditions; or (c) the failure of the Buyer or any other party to maintain the products properly; or (d) any failure resulting from causes external to the products after delivery; or (e) any failure resulting from modifications to the products other than modifications made by Mid-State. Mid-State shall not in any event be liable for any costs incurred by Buyer, including, without limitation, the cost of any labor expended on any product.

MID-STATE MAKES NO WARRANTIES, OTHER THAN THE LIMITED WARRANTY SPECIFIED ABOVE, OR REPRESENTATIONS, EXPRESS OR IMPLIED, WITH RESPECT TO THE PRODUCT OR ANY SERVICE, ADVICE, OR CONSULTATION, IF ANY, FURNISHED TO THE BUYER OR ANY OTHER PARTY BY MID-STATE OR ITS REPRESENTATIVE. MID-STATE SPECIFICALLY DISCLAIMS THE IMPLIED WARRANTIES OF MERCHANTABILITY AND FITNESS FOR A PARTICULAR PURPOSE. THE REMEDIES SET FORTH ABOVE ARE THE ONLY REMEDIES AVAILABLE TO ANY PERSON FOR BREACH OF ANY COVENANT, DUTY OR OBLIGATION ON THE PART OF MID-STATE HEREUNDER. MID-STATE SHALL NOT BE LIABLE FOR ANY LOSS, PERSONAL INJURY OR PROPERTY DAMAGE DIRECTLY OR INDIRECTLY ARISING FROM THE USE OF SUCH PRODUCT, ADVICE OR SERVICE, OR FOR INCIDENTAL, CONSEQUENTIAL OR PUNITIVE DAMAGES OF ANY DESCRIPTION, WHETHER ANY SUCH CLAIM BE BASED UPON WARRANTY, CONTRACT, NEGLIGENCE, STRICT LIABILITY OR OTHER TORT, OR OTHERWISE.



CONTROL PANEL CONTROLS & ELECTRICAL LAYOUT

Medical Equipment Washing & Decontamination Systems



Front View of Control Panel

MALE / FEMALE WIRE CONNECTORS TO REMOTE DEVICES

Wash Cycle Counter

Depending on your year and model, it may be located in the Chemical Cabinet, under the Chemical Pumps.

Drive Motor Capacitor

FUSES: 120V Operation

- FU-1: FRN-R-20
- FU-2: FNQ-R-5
- FU-3: GMD-2.5
- FU-4: GMD-1.5
- FU-5: GMD-1.5
- FU-6: GMD-1.5
- FU-7: FNQ-R-8

Chamber Pump Motor Contractor

Drain Pump Motor Relay

Power Supply 30 Watt, 24V DC

Control Switches

PLC

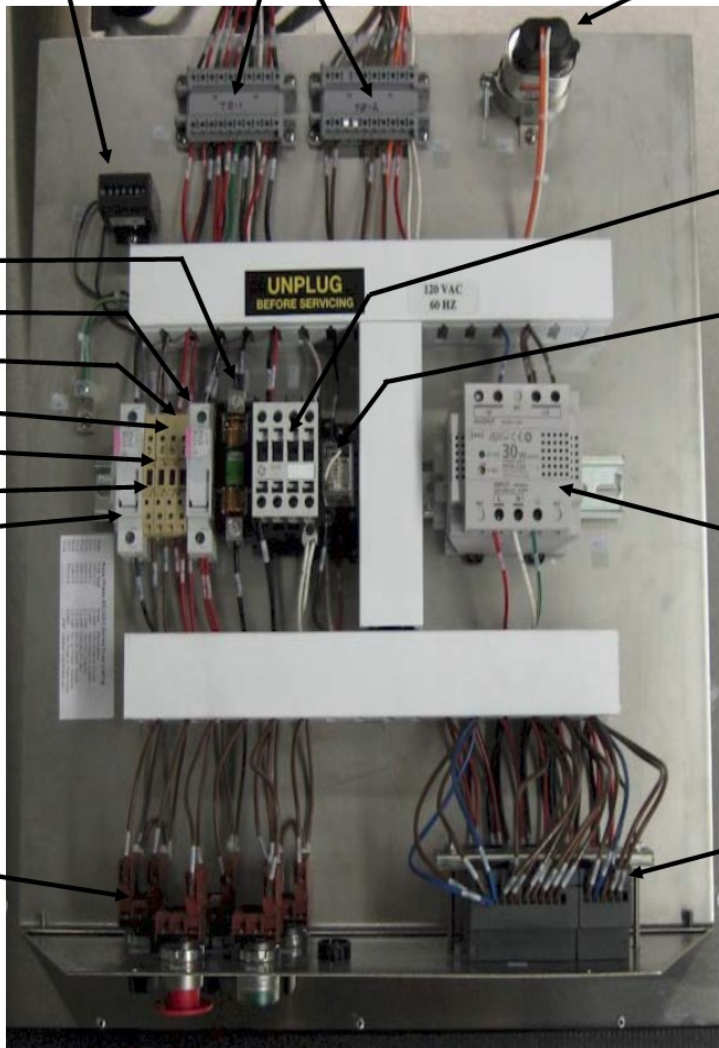

Top View of Control Panel, after cover has been removed.



FUSES

Medical Equipment Washing & Decontamination Systems

The critical electrical devices on **Aqua Phase** are protected by fuses from electrical anomalies. Without a properly fused electrical system, there would be risks to the critical (*expensive*) electrical devices and to a person operating the device.

IF YOU SUSPECT A FUSE MAY BE BLOWN, UNPLUG THE MACHINE BEFORE INVESTIGATING.

Seven fuses and a GFCI are located on **Aqua Phase**:

CONSULT THE WIRING DIAGRAM AS THIS FUSE LIST MAY CHANGE PENDING FEATURES AND OPTIONS

NAME	FUSE TYPE	PURPOSE	LOCATION
FU-1	RFK 20A (FRN-R-20)	Pump Motor - Main Power	Control Panel
FU-2	CC 5A (FNQ-R-5)	Electronics System	Control Panel
FU-3	GMD 2.5A (GMD-2.5A)	PLC Outputs	Control Panel
FU-4	GMD 1.5A (GMD-1.5A)	Drive Motor	Control Panel
FU-5	GMD 1.5A (GMD-1.5A)	Safety Switches & Probes	Control Panel
FU-6	GMD 1.5A (GMD-1.5A)	PLC Inputs (<i>Switches</i>)	Control Panel
FU-7	CC 8A (FNQ-R-8)	Drain Pump	Control Panel
FU-8	-	Optional (<i>Light, Blower, etc</i>)	Control Panel
GFCI	GFCI	Ground Fault Protector	Power Cord

Effects of a blown fuse(s):

NAME	STATUS	CONDITION
FU-1	If Blown	No power to main pump, no water spraying in wash chamber.
FU-2	If Blown	System will be "dead."
FU-3	If Blown	No activity from pressing "START" button.
FU-4	If Blown	System will pump, but no sweeping spray action will be heard.
FU-5	If Blown	No activity from pressing "START" button.
FU-6	If Blown	No activity from pressing "START" button.
FU-7	If Blown	No Power to drain pump. Machine will not drain.
GFCI	If Tripped	System will be dead. No power to any devices.

Fuses listed above (*with the exception of the "GFCI"*) are located behind the control panel face.

To access fuses on the control panel:

1. Remove the fasteners on the left and right of the control panel cover as it is secured to the top of the Aqua Phase unit (*4 screws total – two on each side*).
2. You need to **remove only the top two** screws on the control panel face.

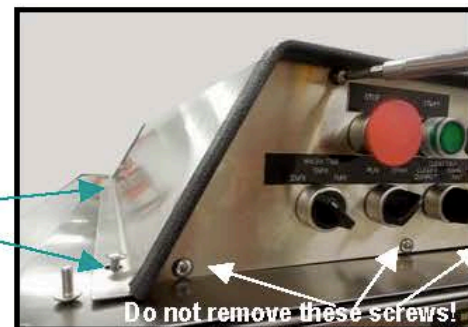



WIRE DIAGRAMS

Medical Equipment Washing & Decontamination Systems

MODEL	AQUA PHASE	Software	Cadkey 97	OPTIONS SHOWN	OPTIONS SHOWN/SPECIAL
DATE	4-10-2013	Directory	AQ-CONTROLS & WIRING	DISINFECTANT APP. SYSTEM	120 VOLT 60 HZ SYSTEM
PAGE	1 OF 3	Levels	1	WHEEL ROTATION SYSTEM	
FILE	AQ-8000 WIRE DIAGRAM	Controller	LOGO 12/24RC & DM8 24R	LIGHT WASH CHAMBER	VERSION 8 HARDWARE
		REV:5-2-13	REV 5-25-17	REV 6-20-17	PDF FILE:NONE

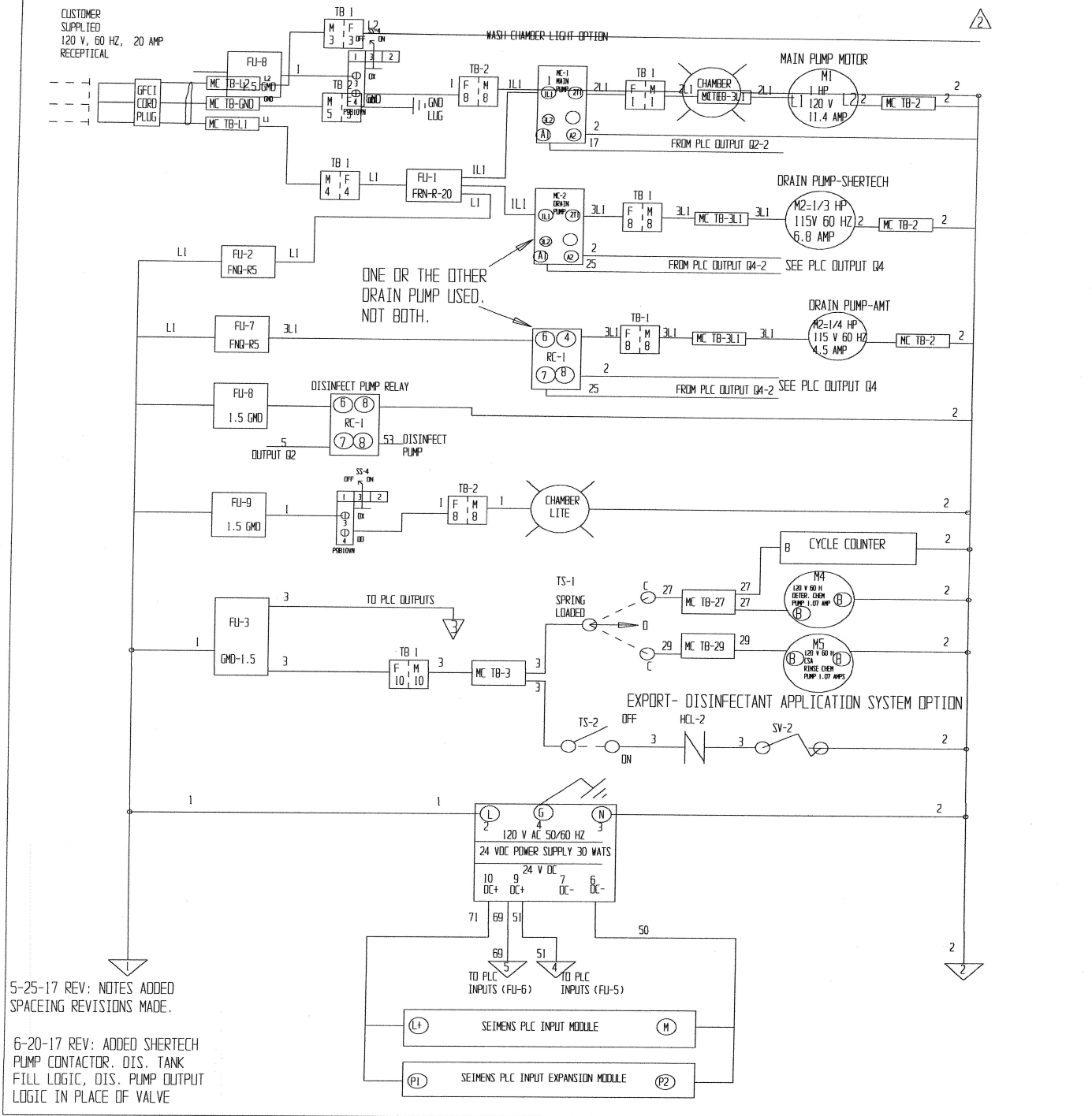



WIRE DIAGRAMS

Medical Equipment Washing & Decontamination Systems

MODEL	AQUA PHASE	Software	Cadkey 97	OPTIONS SHOWN	OPTIONS SHOWN/SPECIAL
DATE	4-10-2013	Directory	AQ-CONTROLS & WIRING	DISINFECTANT APP. SYSTEM	120 VOLT 60 HZ SYSTEM
PAGE	2 OF 3	Levels	1	WHEEL ROTATION SYSTEM	
FILE	AQ-8000 WIRE DIAGRAM	Controller	LOGO 12/24RC & DMB 24R	LIGHT WASH CHAMBER	VERSION 8 HARDWARE
FIELD WIRING DIAGRAM #:	3K-7	REV:5-2-13	REV 5-25-17	REV 6-20-17	PDF FILE:NONE

PLC INPUTS

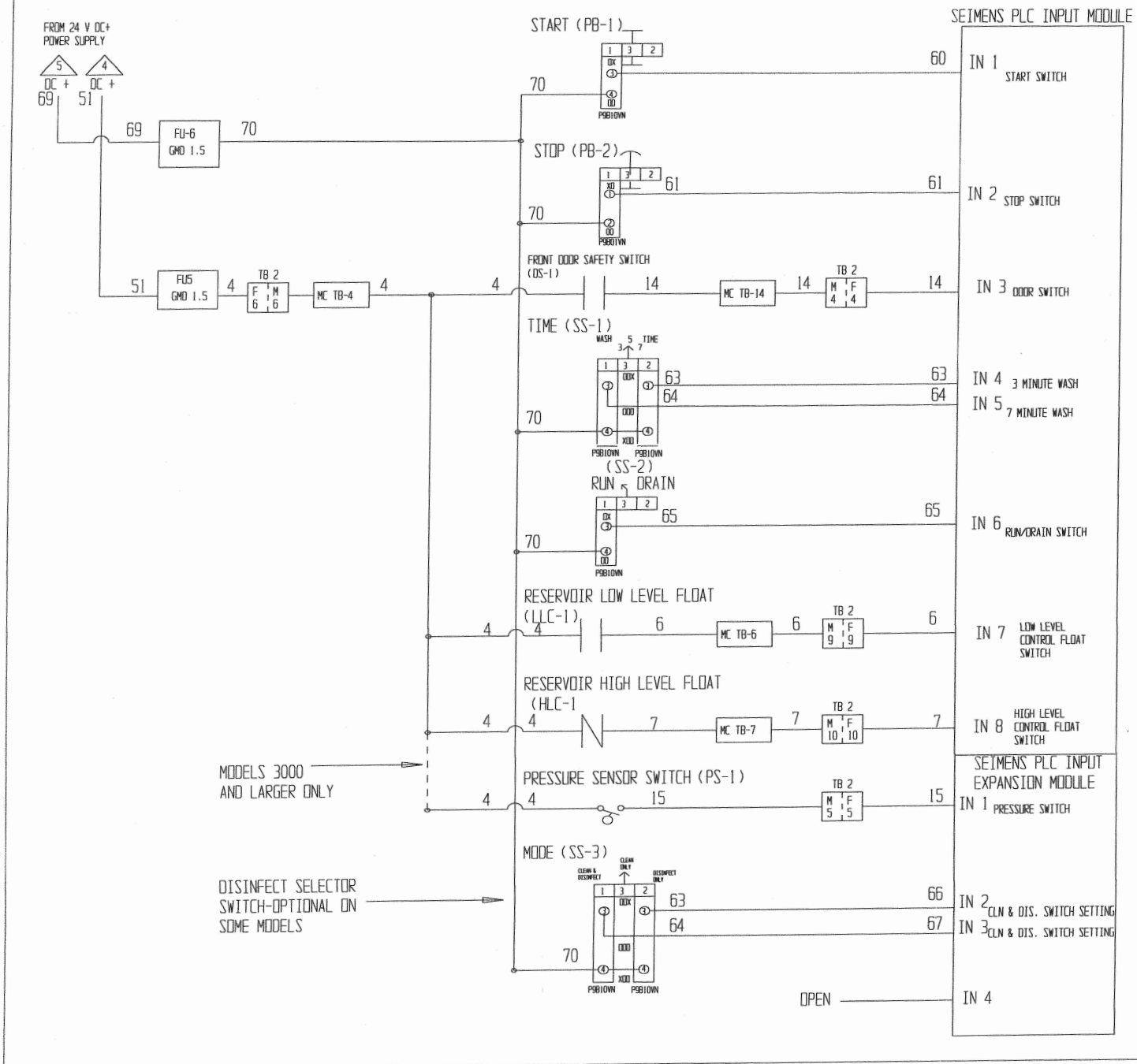



WIRE DIAGRAMS

Medical Equipment Washing & Decontamination Systems

MODEL	AQUA PHASE	Software	Codkey 97	OPTIONS SHOWN	OPTIONS SHOWN/SPECIAL
DATE	4-10-2013	Directory	AQ-CONTROLS & WIRING	DISINFECTANT APP. SYSTEM	120 VOLT 60 HZ SYSTEM
PAGE	3 OF 3	Levels	1	WHEEL ROTATION SYSTEM	
FILE	AQ-8000 WIRE DIAGRAM	Controller	LOGO 12/24RC & DMB 24R	LIGHT WASH CHAMBER	VERSION B HARDWARE
			REV:5-2-13 REV 5-25-17 REV 6-20-17		PDF FILE:NONE

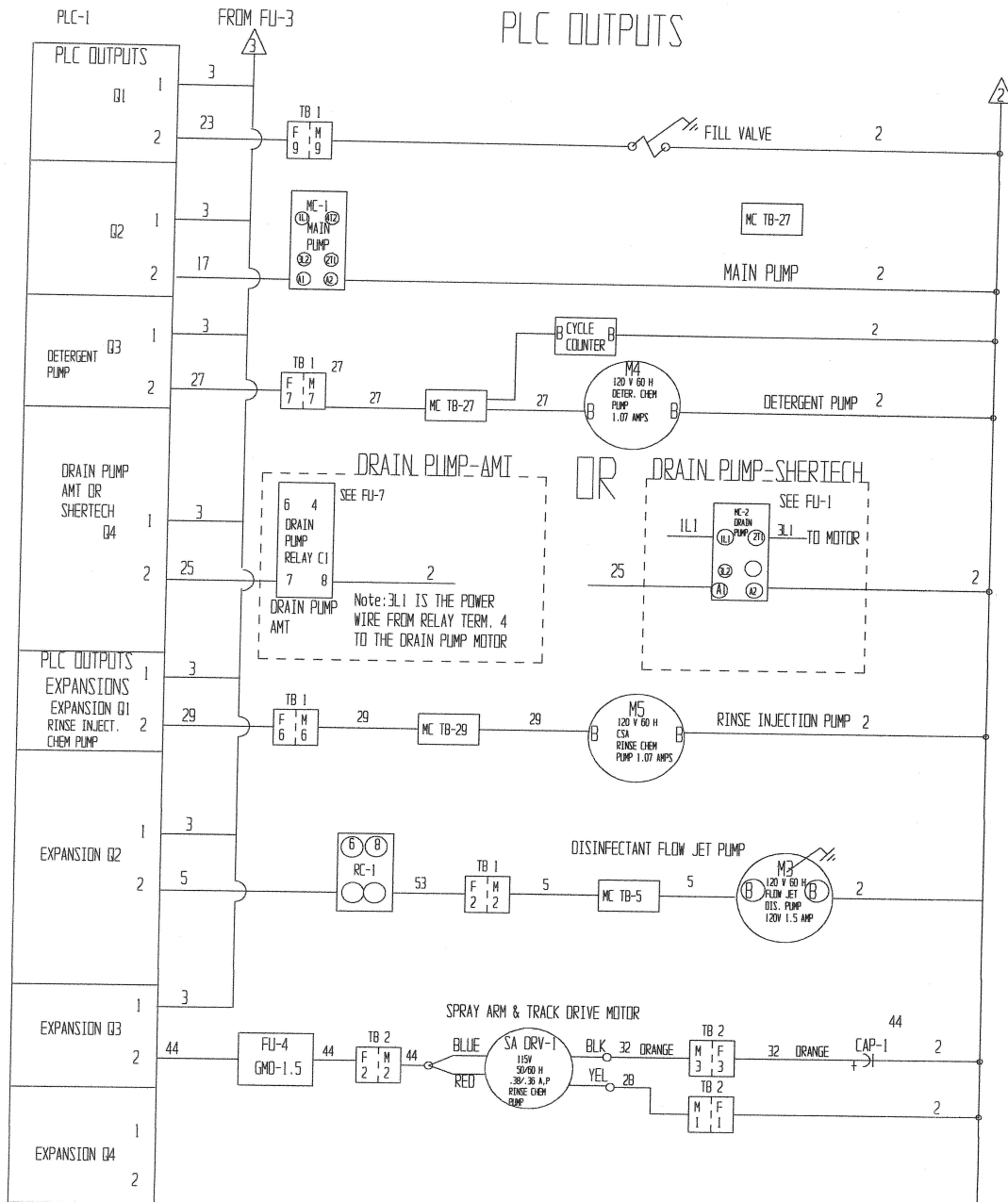



DOMESTIC PARTS LISTING

Medical Equipment Washing & Decontamination Systems

Qty	Item	Description	UM	STATUS	YEAR	Notes - Where Used
CAROUSEL DRIVE PARTS						
1	321-6494K3	8K FLANGE BEARING 2-BOLT NICKEL 1" Bore	Each	Std		Exterior Drive Shaft Bearing
3	321-6357K47	8K FLANGE BEARING 2-BOLT ACETAL 1" BORE	Each	Std		Deck, Tans Plate, Ceiling
1	321-1f570	8K FLNG BEARING 2-BOLT SS STAMPED 1" UHMW	Each	Std		Bottom of Trans Plate
1	321-665K42	8K THRUST BEARING 1" BORE	Each	Std		Ceiling & Under Carousel
3	3376K2	CAROUSEL DECK PERIMETER BEARING	Each	Std		5/8 Dia-1/4" stud
27"	324-FGSATL3500	CHAIN-DELRIIN-35 PITCH	Lin. Ft.	Std or Option		Drive Chain-27" Long
2	5M125-0	COTTER PIN-3/16 X 3 STAINLESS	Each	Std or Option		40 Tooth Sprocket Pin
1	323-35BF101/2	SPROCKET-DRIVE MOTOR-10 TOOTH FORGED 1/2:	Each	Std or Option		
2	M8-49-110	SPROCKET-DRIVE SHAFT 40 TOOTH 1" BORE	Each	Std or Option		
CHEMICAL INJECTOR PUMPS						
2	225-35718	CHEM PUMP & MOTOR-BETA-115V,50/60HZ	Each	Std		Chem pump - Beta brand (green covers).
2	225-59967	CHEM PUMP FRONT COVER: HSG,8 0	Each	Std		Chem pump - Beta brand (green covers).
2	225-22028	CHEM PUMP HOSE - YELLOW	Each	Std		Hose inside chemical pumps
2	225-3518M	CHEM PUMP MOTOR ONLY	Each	Std		Motor only for Beta pump head
2	225-38850	CHEM PUMP REAR COVER: HSG ASSY	Each	Std		Chem pump - Beta brand (green covers).
2	225-51189	CHEM PUMP ROLLER ASSEMBLY	Each	Std		Chem pump - Beta brand (green covers).
2	255-810-105-405	CHEM PUMP-ANKO 58 RPM	Each	Std	5/1/2017	AQ Units After 5-1-2017 (clear covers)
1	XM3-68-015	DETERGENT SUCTION HOSE-RED	Each	Std	5/1/2017	2017-Replaced with Yellow Hose-1/4" poly
1	XM3-68-005	RINSE SUCTION HOSE-BLUE	Each	Std		1/4" poly
DISINFECTANT APPLICATION SYSTEM-Standard and Optional						
1	151-5532K644	ADP POL EL 3/8POLY X 3/8MNPT	Each	Std		Disinfect Ceiling Arm
4	151-5532K422	ADP POL STRT 1/4POLY X 1/4MNPT	Each	Std		Disinfectant Ceiling Arm-Data Collection Sys.
1	151-5532K488	ADP POL STRT 3/8POLY X 1/4MNPT	Each	Std		Inlet end of Dema Injection Valve
1	138-24.11MP	DEMA FOOT STRAINER	Each	Std		Disinfectant Chemical Tubing Hose Strainer
1	138-204CT	DEMA VALVE INJECTOR 1/2" THREAD	Each	Std		Disinfectant Chemical Injector - 1/2"
1	138-202CT	DEMA VALVE INJECTOR 1/4" THREAD	Each	Std		Disinfectant Chemical Injector - 1/4"
4 to 8'	138-100.12	DEMA VINYL TUBING	Lin. Ft.	Std		Disinfectant Chemical Suction Tubing
TRACK AND TRACE (SYSTEM VALIDATION OPTION)						
1	134-4RC67	FLOW SWITCH VALVE 3/4NPT	Each	Option		Data Collections System
1	275-PRINT-UPGRD	PRINTER-OMNI PRINT	Each	Option		Data Collections System
1	275-PRINT PAPER	PRINTER-OMNI PRINT-PAPER	Each	Option		Data Collections System
1	275-PRINT CONN	PRINTER-OMNI PRINT-PRINTER CABLE	Each	Option		Data Collections System
1	275-7675K5	PROXIMITY SENSOR 12MM	Each	Option		Data Collections System
1	255-M90-19-B1A	UNITRONICS CNTRLR M90-19-B1A	Each	Option		Data Collections System
1	255-M91-2-UN2	UNITRONICS CONTROLLER	Each	Option		Data Collections System
1	255-EX-A1	UNITRONICS EXPANSION ADAPTER	Each	Option		Data Collections System
1	255-I/O-D18-R04	UNITRONICS EXPANSION MODULE	Each	Option		Data Collections System



DOMESTIC PARTS LISTING

Medical Equipment Washing & Decontamination Systems

CONTROL PANEL ASSEMBLY COMPONENTS (2004 forward)						
1 to 3	277-3M533	CAPCITOR MOUNTING KIT	Each	Std & Option		Electrical Components
1 to 3	277-97-F5705BX	CAPCITOR, RUN 5MFD 370 V	Each	Std & Option		Electrical Components
1	277-P9B01VN	CONTACT BLOCK GE 1 NC-STOP BTN	Each	Std		Electrical Components
1	277-P9B10VN	CONTACT BLOCK GE 1 NO - 3POS	Each	Std & Option		Electrical Components
1	277-CL00A310TJ	MOTOR CONTACTOR GE 3HP/230	Each	Std		Electrical Components
1	256-21MD000BA5	PLC-SIEMENS LOGO CONTROLLER	Each	Std		Version 8
1	256-51HB000BA0	PLC-SIEMENS LOGO EXPANSION MODULE	Each	Std		Version 8
1	278-PS5R-C24	POWER SUPPLY 30 WATT 24VDC	Each	Std		Electrical Components
2	277-P9MSMD0N	SWITCH GE 2 POS BLK KNOB	Each	Std & Option		Run/Drain & Lighted Wash Chamber Switch
2	277-P9MSMZ0N	SWITCH GE 3 POS BLK KNOB	Each	Std & Option		Wash Time & Wash Mode Switch
1	277-P9MPLVGD	SWITCH GE START BUTTON - GREEN	Each	Std		Green Start Button
1	277-P9MEM4RN	SWITCH GE STOP BUTTON 40MM RED	Each	Std		Red Stop Button on Control Panel
4	238-9080GR6	TERM BLK M/C - LARGE BLOCK	Each	Std		Electrical Components
8	238-9080GM6	TERM BLK M/C - SMALL BLOCK	Each	Std		Electrical Components
CONTROL-FUSES						
3 to 5	237-GMD 1.5A	FUSE 1.5 AMP GLASS TUBE	Each	Std		SA Drv Mtr, C-Pumps Inputs, Switches, Floats
1	237-FRN-R-2	FUSE 2 AMP FRN CARTDGE	Each	Std		Control circuit-Drain Pump
1 to 3	237-6F057	FUSE 2 AMP GLASS TUBE	Each	Std		Chemical Pump Fuse
1	237-GMA 2.5	FUSE 2.5 AMP GLASS TUBE	Each	Std		PLC Outputs
1 or 2	237-FRN-R-20	FUSE 20 AMP FRN CRTRDGE (RFK)	Each	Std		Pump Motors & Main System Fuse
1	237-FNQ-R-5	FUSE 5 AMP CC MINI CRTRDGE (kdr-5)	Each	Std or Option		Transf (240v) Elect Sys (110v)-Drain pump
1	237-FRQ-R-8	FUSE 8 AMP CC MINI CRTRDGE (kdr-8)	Each	Std		Drain pump
GFCI						
1	234-54880R	GFCI-120V, 20 AMP NO POWER CORD	Each	Std		
1	234-2000-0050	GFCI-120V, 20 AMP WITH POWER CORD	Assembly	Std		
1	234-7228K13	GFCI-230V, 20 AMP WITH CORD	Assembly	Std or Option		Ground Fault Circuit Interrupter
1	234-7228K13	GFCI-230V, 20 AMP NO POWER CORD	Each	Std or Option		
CONTROL PANEL ASSEMBLY COMPONENTS (PRE 2004)						
1	M3-3K FULL	CONTROL ASSEMBLY-2017 MODICON REPLACED	EA	Std		
1	235-SL1-D	FRONT DOOR LIMIT SWITCH-HONEYWELL	Each	Not-Std	Pre-2004	Mounted in wash chamber
2	M321-201	LEVEL PROBE ASSM - ROD STYLE	Each	Not-Std	Pre-2004	Sump high & low probes - Metal Rod Style
2	277-0900	LEVEL PROBE SENSOR POD ORANGE	EA	Not-Std	Pre-2004	Sensor Pod for Rod Style Level Probes
1	254-110CPU31101	MODICON PLC	EA	Not-Std	Pre-2004	Computer (old style)
4	277-BA9S130	PILOT LIGHT- BULB 130 V	Each	Not-Std	Pre-2004	Electrical Components - Pilot Light Bulb



DOMESTIC PARTS LISTING

Medical Equipment Washing & Decontamination Systems

CONTROLS- SWITCHES, SENSORS, LEVEL CONTROLS					
1 or 2	235-2XC13	FLOAT SWITCH - HORIZONTAL LEVEL	Each	Std	Water Level High Float - Plastic Float Style
1	235-2A554	FLOAT SWITCH - VERTICAL LEVEL	Each	Std	Water Level Low & High Float - Plastic Float Style
1	235-B11-204	LIMIT SWITCH-FR/DR 80-348 XTRN	Each	Std	Front door -white switch (lever type)
1	136-41535K91	PRESSURE SWITCH 1/4NPT 5-65PSI	Each	Option	Low Pressure Cntrl Switch (Get Nipple too)
1	235-SS208CBG	TOGGLE SWITCH ON/OFF (DIS TANK)	Each	Std	Units With Disinfectant Water Holding Tank
1	235-GSW-13	TOGGLE SWITCH 3POS CHEM PUMP	Each	Std	Chemical Pump Primer Switch
FILTERS & SCREENS					
1	141-15839-75	FILTER CART HOUSING 1/2" NPT (CART 10 MIC FILTS)	Each	Option	Without Plumbing Fittings
1	141-EPM-10	FILTER CART-10 MICRONS	Each	Option	
1	170-10373	FILTER SCREEN, FILL PORT 1	Each	Std	Filter Screen located inside Fill Line Hose (wash)
1	M8-16-010	RESERVOIR FILTER SCREEN -8K LARGE	Each	Std	
1	AQ-170	WATER FILTRATION ASSM 1/2 NPT	Assembly	Option	Housing W/Plumbing & 2 10 mic carts
GASKETS					
1	M8-75-001	FRONT DOOR GASKET 8k	Each	Std	240" Trim to fit.
1 or 2	XM4321-75-085	FRONT DOOR WINDOW GASKET	Each	Std or Option	Front Window Gasket
TUBING, HOSES, FITTINGS (AND ACCESSORIES)					
1	151-5532K444	ADP POL STRT 3/8POLY X 3/8MNPT	Each	Std	Interior Disinfect lines
1	151-5532K644	ADP POL EL 3/8 POLY X 3/8 MNPT	Each	Std	Interior Disinfect lines
1	151-5532K822	ADP POL TEE 1/4POLY X 1/4MNPT	Each	Std	Chem hose connect at reservoir
9	126-SSCLJ HD	1-1/2" TRI-CLAMP CLAMP HD	Each	Std	Ceiling, Chamber, Main Pump
9	126-100-0270	1-1/2" TRI-CLAMP GASKET-BUNA	Each	Std	Ceiling, Chamber, Main Pump
1	126-SSCLK HD	2" TRI-CLAMP CLAMP HD	Each	Std	Main Pump Connection
1	126-100-0280	2" TRI-CLAMP GASKET-BUNA	Each	Std	Main Pump Connection
16"	170-HPD-6 41662	HOSE 1 BLACK	Lin. Ft.	Std	Drain Pump Suction
2	175-5413K54	HOSE CLAMP 1 SS #16 1-1.5 DIA	Each	Std	Drain Pump Suction
1	176-5372K135	HOSE BARB STRGHT 1" X 1" MNPT	Each	Std	Drain Pump Suction
1	176-5372K333	HOSE BARB 90 1" X 1" MNPT	Each	Std	Drain Pump Suction
30"	170-HPD-9 61662	HOSE 1-1/2 BLACK	Lin. Ft.	Std	Main Pump Discharge
2	175-5413K57	HOSE CLAMP 1-1/2 SS #28	Each	Std	Main Pump Discharge
2	176-689-4618	HOSE BARB STRGHT 1-1/2 X 1-1/2" MNPT	Each	Std	Main Pump Discharge
42"	170-102-1000	HOSE 3/4 BLACK	Lin. Ft.	Not-Std	Disinfectant Pump
1	176-5372K333	HOSE BARB 90 EL 3/4 X 3/4 MNPT	Each	Not-Std	Disinfectant Pump
2	175-5413K52	HOSE CLAMP 3/4 SS #10	Each	Not-Std	Disinfectant Pump
2	170-70815T43	HOSE CONNECT 1/2 GARDEN FEMALE	Each	Std	Fill and Drain connections
1	170-10031640	HOSE FILL OR DRAIN 10-FOOT LONG	Each	Std	Vulcanize hose ends 180 degree rating.
1	170-62215T78	HOSE-WASHER-DRAIN LINE	Each	Std	
1	1110-GNBK	NIPPLE 1/4 X 2 GALVINIZED	Each	Std & Option	For Pressure Switch
28"	172-1B02507	POLY TUBE 1/4 BLUE (SOFT)	Lin. Ft.	Std	Chemical Rinse Suction Hose



Medical Equipment Washing & Decontamination Systems

54"	172-0140	POLY TUBE 1/4 NATURAL (SEMI RIDGID)	Lin. Ft.	Std		Chemical Injection Hose - Into Wash Chamber
28"	172-1B02508	POLY TUBE 1/4 YELLOW (SOFT)	Lin. Ft.	Std		Chemical Detergent Suction Hose
32"	172-0340	POLY TUBE 3/8 NATURAL (SEMI RIDGID)	Lin. Ft.	Std or Option		Drip Tube to Reservoir
MISC						
1	AQ-195	AQ OPERATIONS MANUAL	Each	Std		AQ-4000 Operations Manual - Printed & Bound
1	340-6X10-1/8	GLASS - LIGHTED CHAMBER WINDOW	Each	Std or Option		Lighted Wash Chamber Replacement Window
1	340-12X12X.030	GLASS - FRONT DOOR WINDOW	Each	Std or Option		Safety Glass Replacement Window
1	291-LAM 100ARS	LITE BULB -FOR CHAMBER FIXTURE	Each	Std or Option		Rough Service Bulb -Lighted Chamber Opt.
NOZZLES						
16	161-NBDIS	NOZZLE 1/4 .25 GPM FULL CONE DIS. SYS.	Each	Std		Disinfect System
29	161-NBF1565	NOZZLE 1/4 1.5 GPM 65D FLAT FAN	Each	Std		Current (Part of Wheel Rotation Sys. Opt.)
	161-NBF1540	NOZZLE 1/4 1.5 GPM 40D FLAT FAN	Each	Std		AQ-4000 Systems
PUMPS & MOTORS						
1 TO 3	211-4Z062	GEAR MOTOR 14 RPM AC - 4K SA	Each	Std or Option		Spray Arm and/or Track Drive Motor
1	EBCDU200/1NB	PUMP - PUMP HEAD ONLY- KIT, 1.5 HP 120/1	Each	Std or Option		Option. Standard=3k, 3.7k & 8K units
1	228-EBACDU200/115D1C	PUMP & MOTOR ASSEMBLY 1.5 HP EBARA	Assembly	Std or Option		Option. Standard=3k, 3.7k & 8K units
1		PUMP IMPELLER ONLY 1.5 HP EBARA CDU 120/1	Each	Std or Option		Option. Standard=3k, 3.7k & 8K units
1	EBS625001	PUMP MECH SEAL	Assembly	Std		Internal Pump Mechanical Seal
1		PUMP MOTOR ONLY 1.5 HP 120V 60HZ 56J-FRAME	Each	Std or Option		Upgrades, 3K,3.7K & 8k Models
1	222-340280085	PUMP MOUNTING FEET	Each	Std		All pumps
1	222-EB165X3	PUMP O-RING EBARA CDU70/5NB-2H	Each	Std		All pumps
1		DRAIN PUMP & MOTOR ASSEM 1.3 HP	Assembly	Std or Option		Shertech pump and motor assembled
1	220-D-HL-6050	DRAIN PUMP-MOTOR ONLY 1/3 HP	Each	Std or Option		For Shertech pump head
1	SHECOMBB1X	DRAIN PUMP-PUMP HEAD ONLY 1/3 HP-BRONZE	Each	Std or Option		Shertech pump head with seal
1	228-3201-96	DRAIN- PUMP & MOTOR-AMT-ALUM CAST	Assembly	Std		Cast Alum. Pump head 1-1/4 x 1-1/4
1	227-4100-512	PUMP FLOJET 115V 3C - 4K DIS	Each	Std or Option		Pump for Disinfectant Application System
1	227-20381-006	PUMP FLOJET KIT 3/4HB QUADPORT	Each	Std or Option		Adaptor kit for Disinfectant Pump
1	227-20403-020	PUMP FLOWJET CHECK VALVE ASSM KIT	Each	Std or Option		
1	227-20403-040	PUMP FLOWJET DIAPHRAGM KIT	Each	Std or Option		
THERMOMETERS						
1	316-38675K13	THERMOMETER °C CONTROL PANEL	Each	Std or Option		International, option
1	316-3946K125	THERMOMETER RND DIAL 3" 1/2NPT	Each	Std		Fill Line Thermometer - Optional
VALVES (SOLENOID & MISC)						
1 TO 3	131-08F22	SOLENOID VALVE-1/2"-PARKER 50/60HZ	Complete	Std & Option		Fill ,& Disinfect Sys.

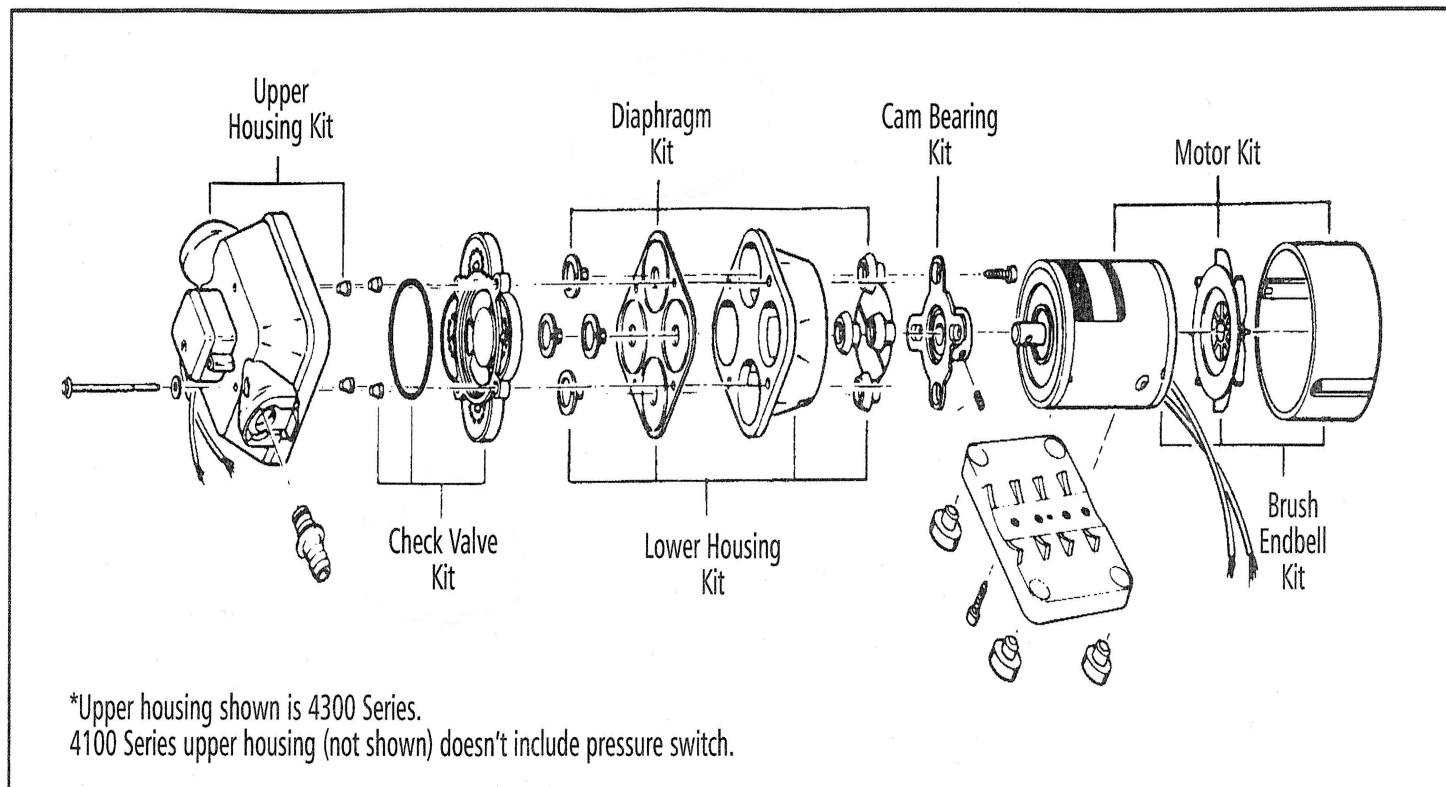

Disinfectant Pump

Medical Equipment Washing & Decontamination Systems





Drain Pump-Shertech

Medical Equipment Washing & Decontamination Systems

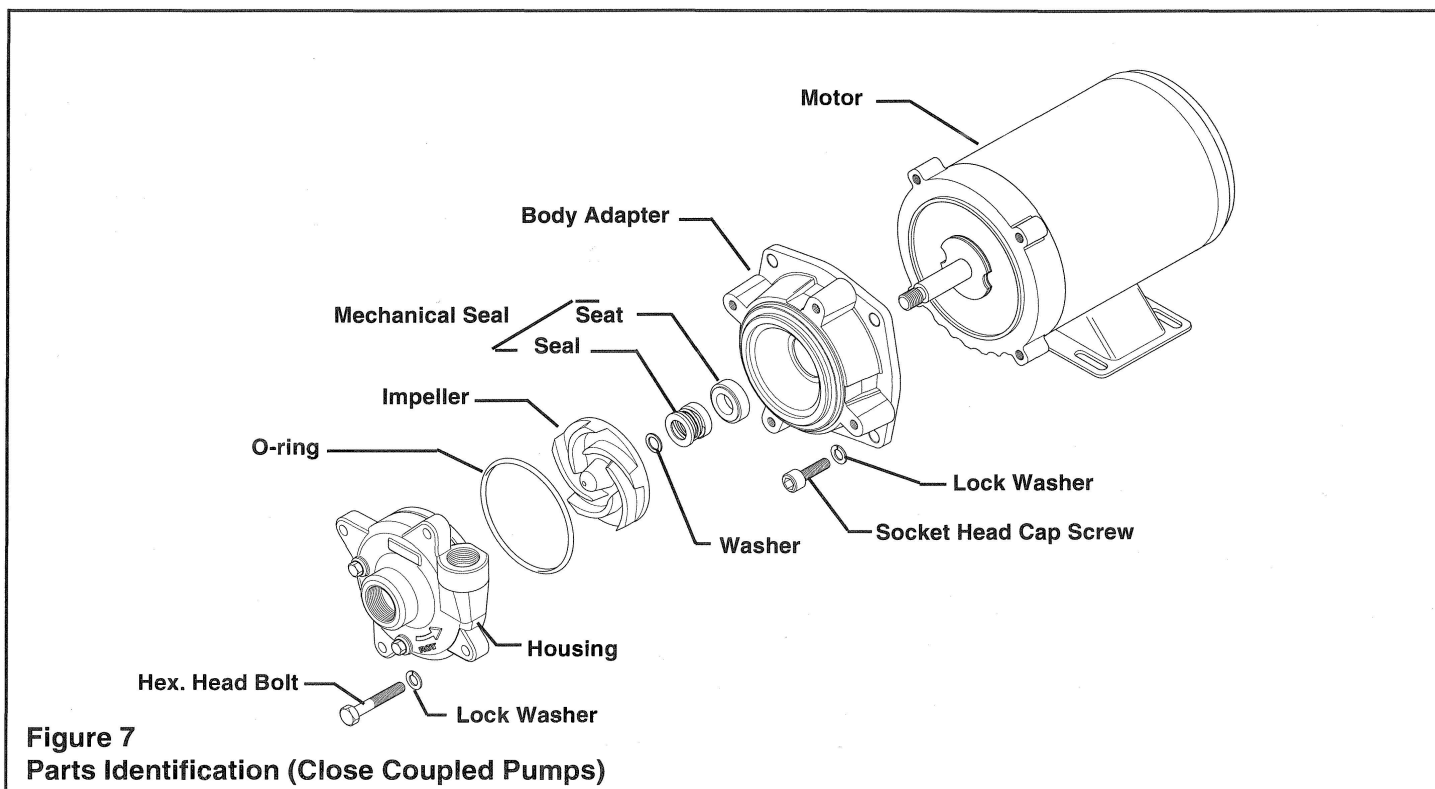
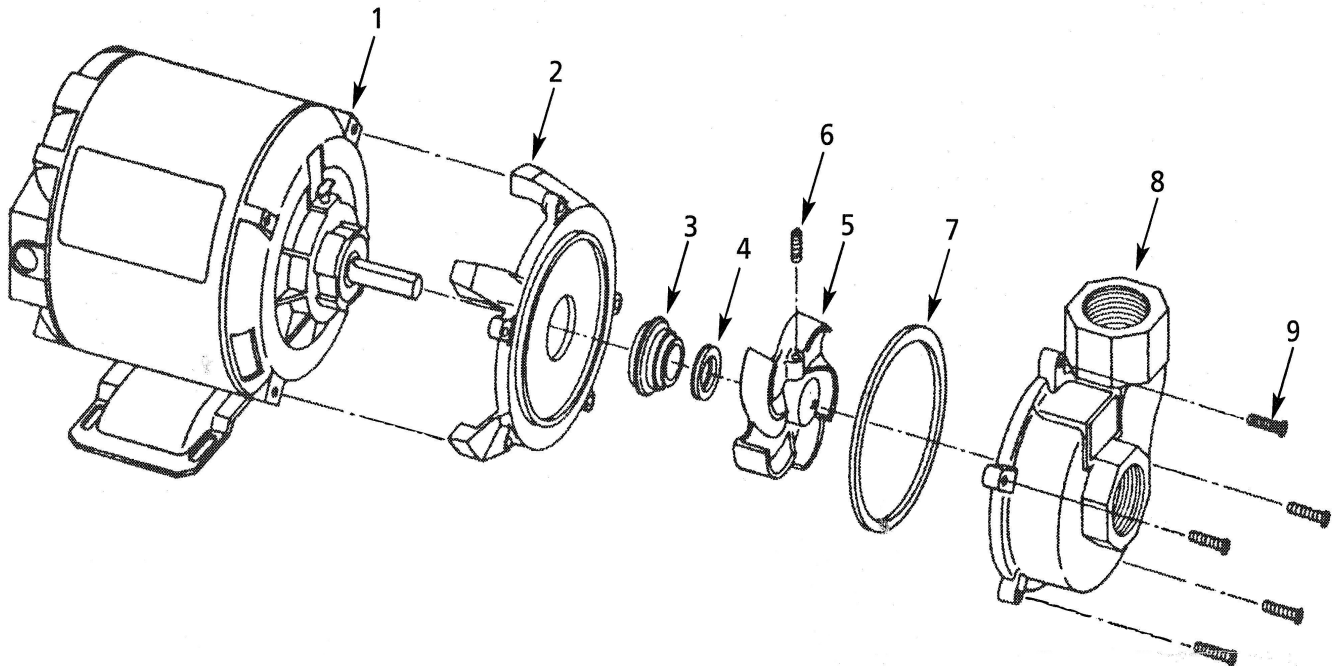

Figure 7
Parts Identification (Close Coupled Pumps)



Drain Pump-AMT

Medical Equipment Washing & Decontamination Systems





TYPICAL CHEMICAL PUMP ASSEMBLY

Medical Equipment Washing & Decontamination Systems

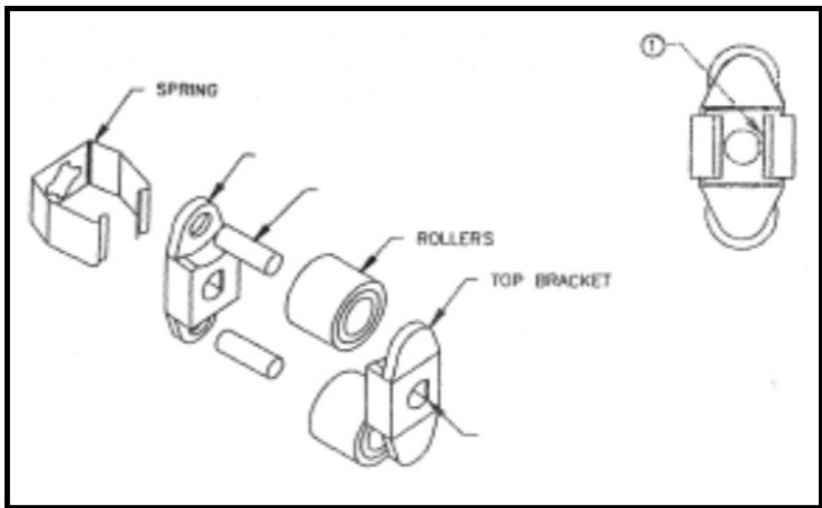
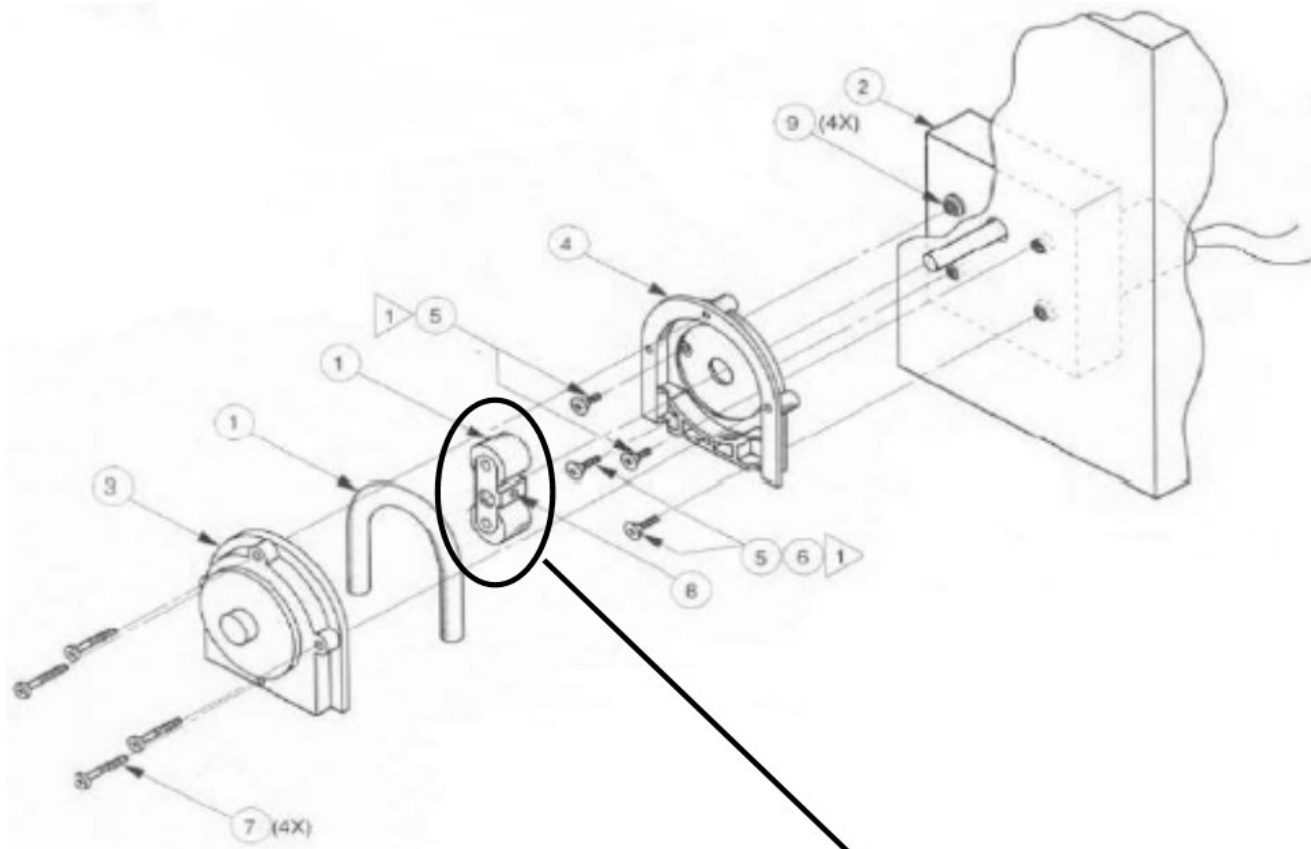



VALVE INSPECTION PROCEDURES

Medical Equipment Washing & Decontamination Systems

The valve inspection can be performed while the valve is still piped in line.

The Valves to be inspected may be:

The Fill Line Valve

The Disinfectant Line Valve

The Drain Valve (pre 2005)

The Main Chamber Valve (Pre 2005).

1. Unplug the Aqua Phase from the power Supply
2. Turn off the water supply to the Aqua Phase
3. Loosen the Fill Line connection (to release water pressure).
4. Remove the Retainer clip or Cap
5. Remove the Data Label Plate if an Asco Valve.
6. Lift the Unit Solenoid (electrical coil) up, off the Plunger Tube Assembly (*Do not miss place the spring or tension clip on the Plunger Tube assembly*).
7. Remove the bolts connecting the valve Cover/Solenoid Base to the valve Body.
8. Separate the valve Cover/Solenoid Base AND the Diaphragm from the valve Body. (*Be not to miss place the springs between the Cover/Solenoid Base and the Diaphragm*). Pay attention to the location of the valve Body Gasket/O-ring.
9. Look at/into the valve Body for and dirt or debris, and remove if any exists.
10. Carefully, separate the Diaphragm for the Cover/Solenoid Base.
11. Inspect the Diaphragm for any damage or wear such as cracking, blisters, or warps. The Diaphragm should have the same pliability/flexibility across its surface.
12. Locate the Bleed Hole (1/2" Valves) in the Diaphragm and make certain it is not plugged or clogged with debris or hard water particles.
13. Check that the Core Spring and Core Assembly moves freely inside the Cover/Solenoid base.

If you find there are issues with items 11, 12, or 13 from above, a valve rebuild kit may need to be ordered and installed.

When reassembling the valve:

IT IS CRITICAL TO THE VALVE OPERATIONS THAT THE BLEED HOLE be towards the "OUT" stamped into the valve Body (*the Bleed Hole will be at about 45 degree from the "OUT" stamp*).

IT IS CRITICAL TO THE VALVE OPERATIONS THAT BOTH THE Core Spring and Diaphragm Spring exist and are in position.



TECHNICAL DATA 1/2" VALVE (FILL & DISINFECT)

Medical Equipment Washing & Decontamination Systems

NORMALLY CLOSED
SERIES 22, WATTAGES A, B & 1
3/8", 1/2" & 3/4" NPT
BRASS-STAINLESS STEEL

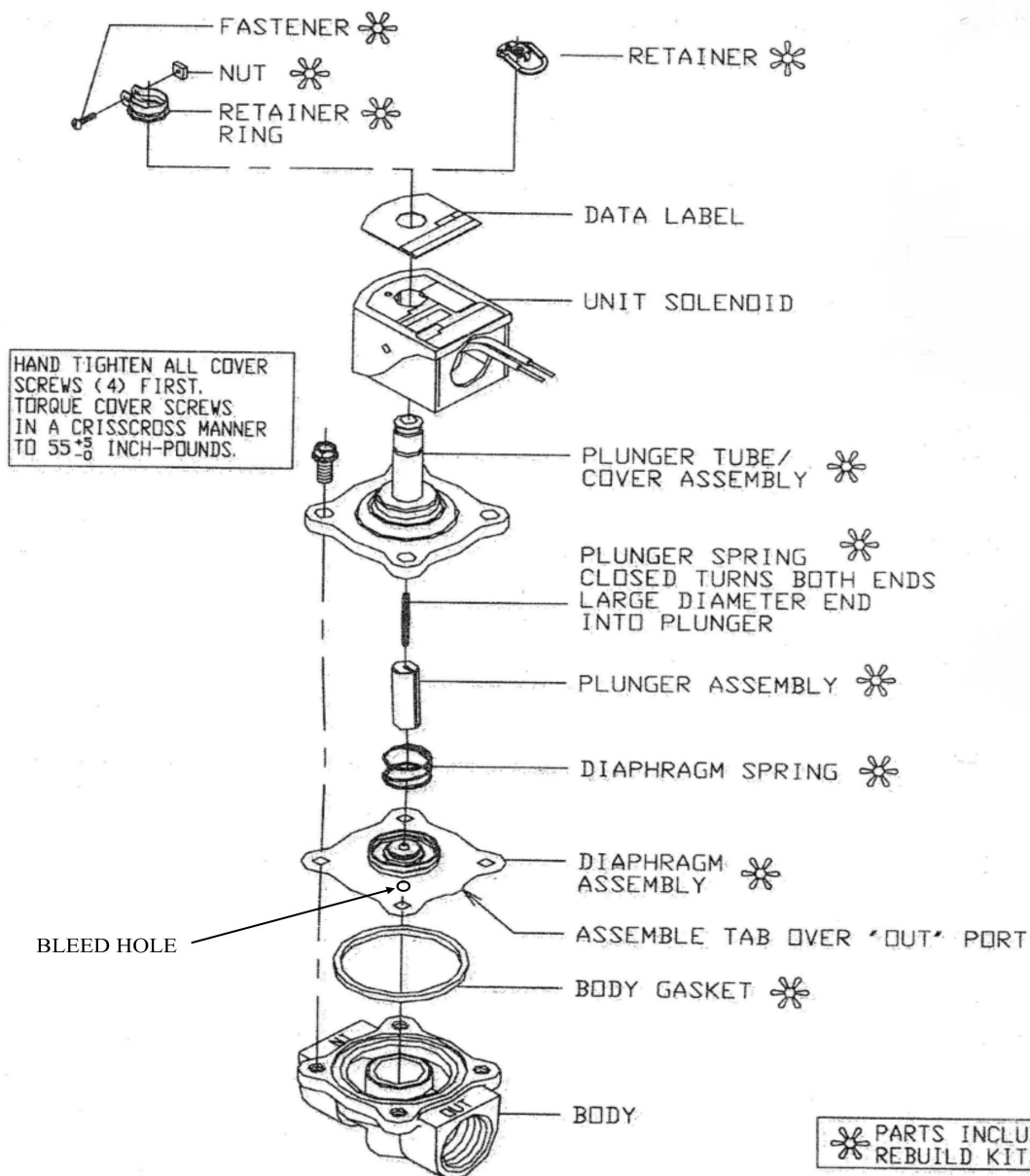



TECHNICAL DATA DISINFECTANT MIXING VALVE

Medical Equipment Washing & Decontamination Systems

DEMA

SINGLE-STAGE INJECTOR MODELS 200-3C, 200C, 201C, 202C, 203C, 204C, 206C, 208C, 2012C

INSTALLATION INSTRUCTIONS

1. PARTS

- A. Injector.
- B. Drum protector disc.
- C. Three brass nozzle bushings.
- D. Plastic Tubing 8' long with foot strainer.
- E. Backup washer (Models 204C & smaller).

2. INSTALLATION

- A. Selecting the nozzle bushing:
Find the appropriate APPLICATION under Section 4 and use the tables to select one of the three bushings supplied. Push the bushing into the injector inlet, small end first, as far as it will go. See Fig. 1.
- B. Back up washer:
In some applications a flexible hose and shut off gun are used downstream from the injector. When the gun is shut off a momentary back flow can develop and push out the nozzle bushing. To prevent this, place the plastic backup washer behind the nozzle before screwing the injector onto the inlet pipe.
- C. Placement in the water line:
The injector may be installed in a horizontal or vertical line and with the knob in any position below, above, or to the side. Water flow must be in the direction of the arrow on the injector body. If the injector pipe size is different from the line size, use pipe bushings or reducers as required. (Injector selection is based on flow, not line size.)
- D. Connection to chemical supply:
Drop the end of the tubing with the strainer into the fluid product container. Cut the tubing to any convenient length and slip the open end over the injector fitting. The container may be more than 8 feet below the injector (extra tubing required) but injection capacity will be less. Do not place the container above the injector unless the injector is under pressure when not in use. This will prevent free siphoning.
The metal drum protector disc may be used to cover the container opening and to hold the tubing in place. Twist the disc at the slit for easy application.

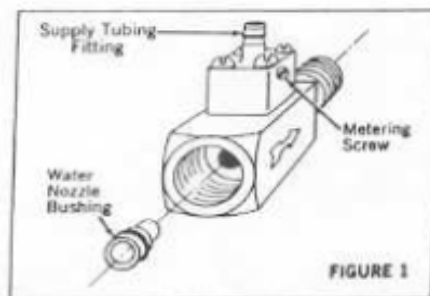

FIGURE 1

3. CHEMICAL FEED ADJUSTMENT

See FIG. 1 for the location of the metering screw in the knob. The knob may be re-oriented for better accessibility by removing the 4 machine screws and turning it to the new position. Turn the metering screw to the left to increase the injection rate. Five turns provide the maximums shown in Table 1. These figures are with 8 feet of suction tubing, a lift of 4 feet from the fluid container to the injector, and for a maximum water temperature of 140°F. Injectors will operate at reduced injection rates up to 200°F or a lift up to 25 feet. If the chemical is viscous (above 75 cps) the maximum injection rates of injectors up to Model 204C can be as much as doubled by using 3/8" ID tubing. (Dema part 100-121.) Use a 1" piece of regular tubing over the inlet barb as a bushing.
Optional "T" type metering knob (see parts list on back page). Screw pre-selected metering tip (fixed orifice) into inlet barb before attaching plastic tubing.

4. APPLICATIONS

SPRAYING SYSTEM AT LINE PRESSURE FIGURES 3 AND 4.

Select the nozzle bushing to match your total spray nozzle flow and pressure as shown in Table 1 on page two. Spray nozzle catalog flow ratings are the most convenient method of determining water flow. Once an injector has been matched to a spray nozzle system, it will continue to function regardless of fluctuations in line pressure, as the water flow will also fluctuate in proportion. Therefore, if your line pressure is unknown, it is permissible to use spray nozzle ratings at any pressure for the purpose of selecting an injector. Flow ratings at 40 psi are the basis of the spray nozzle numbering system and are therefore most frequently used. If there are lengthy piping, hose, or other restrictions between the injector and nozzles, these pressure losses must be added to the rated pressure before entering Table 1 (see Table 12).

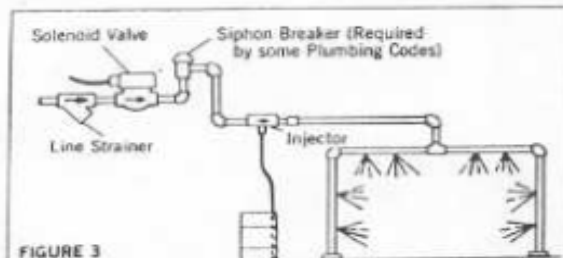

FIGURE 3

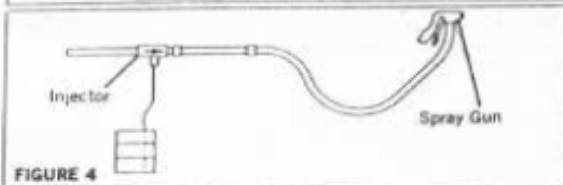

FIGURE 4



SINGLE-STAGE INJECTOR MODELS

200-3C, 200C, 201C, 202C, 203C, 204C, 206C, 208C

Medical Equipment Washing & Decontamination Systems

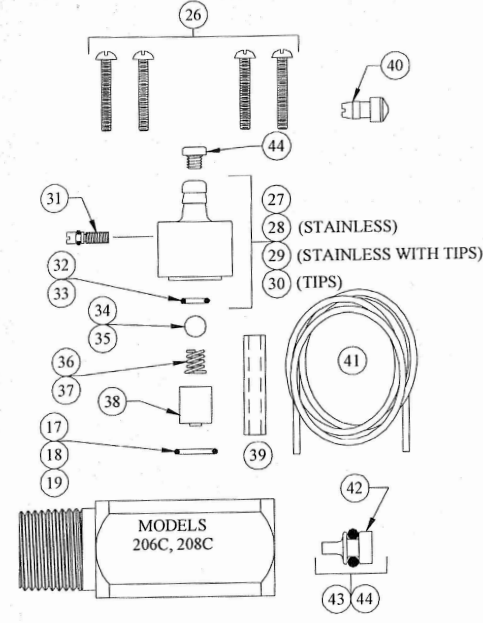
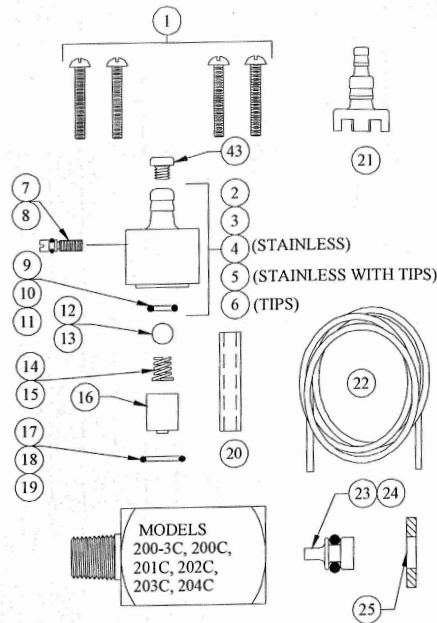

NO.	PART NO.	DESCRIPTION
1	24-33	Screw #8-32 x 7/8" Lg. (4-Reqd.)
2	24-32	Metering Knob Assy.
3	24-32PS	Metering Knob Assy. (-P Injectors)
4	24-32S	Metering Knob Assy. (Stainless)
5	24-32ST	Metering Knob Assy. (Stainless w/Tips)
6	24-32T	Metering Knob Assy. (Tips)
7	100-24	Metering Screw
8	100-24PS	Metering Screw (-P Injectors)
9	24-25	Check Valve O-Ring (EP)
10	24-25S	Check Valve O-Ring (Silicone)
11	24-25V	Check Valve O-Ring (Viton)
12	24-24P	Check Valve Ball (Teflon)
13	24-24S	Check Valve Ball (Stainless)
14	24-23	Check Valve Spring (Stainless)
15	24-23-2	Check Valve Spring (Hastelloy)
16	24-34-	Check Valve Core (Specify Model No.)
17	25-29	Metering Knob O-Ring (EP)
18	25-29S	Metering Knob O-Ring (Silicone)
19	25-29V	Metering Knob O-Ring (Viton)
20	61-107-2	Ceramic Weight for 1/4" ID Tubing for 200-3C Thru 204C
21	24-11MP	Foot Strainer
22	100-12	Vinyl Tubing (3/8" OD x 8' Lg.)
23	24-8-	Water Nozzle & O-Ring Assy. (Brass) Add Num. Stamped on Nozzle
24	24-8S-	Water Nozzle & O-Ring Assy. (Stainless) Add Num. Stamped on Nozzle

NO.	PART NO.	DESCRIPTION
25	24-31	Back-Up Washer (Specify Model No.)
26	23-7	Screw (1" Lg.) (4 Reqd.)
27	23-32	Metering Knob Assy.
28	23-32S	Metering Knob Assy. (Stainless)
29	23-32ST	Metering Knob Assy. (Stainless w/Tips)
30	23-32T	Metering Knob Assy. (Tips)
31	23-24	Metering Screw
32	23-11	Check Valve O-Ring (EP)
33	23-11V	Check Valve O-Ring (Viton)
34	23-10	Check Valve Ball (Stainless)
35	23-10P	Check Valve Ball (Teflon)
36	23-9	Check Valve Spring (Stainless)
37	23-9-2	Check Valve Spring (Hastelloy)
38	23-34-	Check Valve Core (Specify Model No.)
39	61-107	Ceramic Weight for 3/8" ID Tubing for 206C Thru 208C
40	24-11L	Foot Strainer
41	100-12L	Vinyl Tubing (1/2" OD x 8' Lg.)
42	23-8-	Water Nozzle & O-Ring Assy. (Brass) Add Num. Stamped on Nozzle

ACCESSORIES

NO.	PART NO.	DESCRIPTION
43	100-15-	Metering Tip (Specify Color)
	100-15K	Metering Tip Kit
44	61-9	Metering Tip (Specify Color)
	61-9K	Metering Tip Kit



PUMP IMPELLER INSPECTION PROCEDURES

Medical Equipment Washing & Decontamination Systems

WARNING:

Unplug the machine from the power supply before performing any service procedures.

It is recommended that you contact the factory at 800-208-9274 before attempting to clear debris from the pump impeller. Removing debris from the pump impeller requires disassembly of the pump.

1. Unplug the Aqua Phase from the power supply.
2. Disconnect the electrical wires at the pump.
3. Disconnect the clamp going to the inlet of the pump.
4. Disconnect the hose or piping from the pump outlet.
5. Remove the pump mounting nuts.
6. The pump is composed of two components: the pump head and the pump motor.
 - You do not need to remove the pump head from the pump motor.
 - You do need to take the pump head apart.
7. Remove the bolts holding the pump head together.
8. You may need to tap (hit) the pump head assembly to free the two halves.(10 Hex - Socket bolts)
9. Inspect the pump impeller center & Vanes.
 - Check the impeller housing and the inlet elbow for any obstructions, and remove debris if necessary.
10. Inspect the pump o-ring/gasket. Replace if damaged.
 - If your pump needed, you may order a replacement from the Aqua Phase.
11. Reassemble and reinstall the pump.



MAIN SYSTEM PUMP

Medical Equipment Washing & Decontamination Systems

Model CDU, CDX, 2CDU, 2CDX

EBARA End Suction Centrifugal / Two-stage Centrifugal

Instructions and Operation

Exploded view – CDX

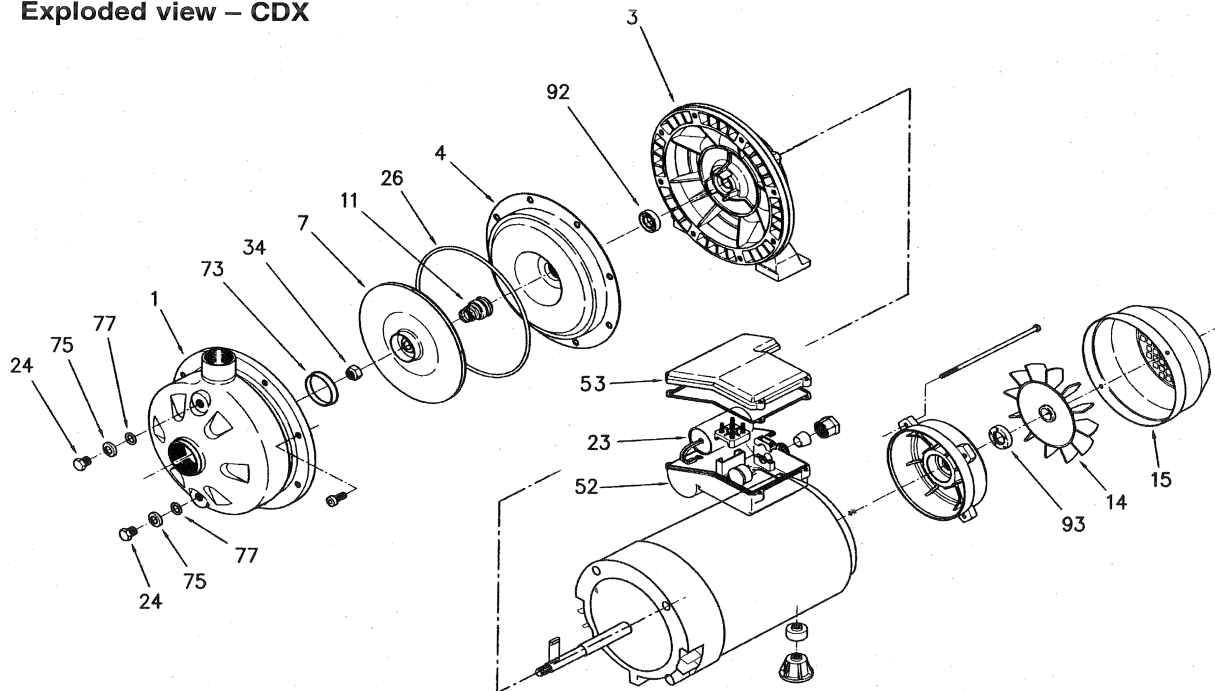

Location No.	Part Name	Material	No. for 1 Unit
001	Casing	304 Stainless	1
003	Motor bracket	Cast Aluminum	1
004	Casing cover	304 Stainless	1
007	Impeller	304 Stainless	1
011	Mechanical seal	Carbon/Ceramic	1
014	Fan	Polypropolene	1
015	Fan Cover	Steel	1
023	Capacitor	Single Phase only	1
024	Priming/Drain plug	303 Stainless	2
026	O-Ring	NBR	1
032	Key	304 Stainless	1
034	Impeller nut	304 Stainless	1
052	Terminal box	Plastic	1
053	Terminal cover	Plastic	1
073	Casing ring	NBR	1
075	Washer	304 Stainless	2
077	O-ring	NBR	2
092	Lip seal	–	1
093	Lip seal	–	1

 EBARA International Corporation
 Standard Pump Division
 (t) 803 327 5005 • (f) 803 327 5097 • info@pumpsebara.com

9
rev. 07/04



TROUBLESHOOTING GUIDE

Medical Equipment Washing & Decontamination Systems

This Guide may help you isolate a problem and as a result, eliminate the need to contact technical support, allowing continued productivity. Prior to attempting any suggested servicing procedures, **unplug Aqua Phase from the power source.**

Contents

Description	Page
Aqua Phase Will Not Start	Page 37
Aqua Phase Will Not Fill With Water	Page 38
Aqua Phase Will Not Stop Draining / Draining Takes Too Long	Page 39
Aqua Phase Will Not Stop Filling / Error Message: Fill Time Expired	Page 40
Items Washed Have Water Spots or Cloudy Film.	Page 41
Items Not Cleaned Properly.	Page 42
Growling Noise Pump (NEEDS EDIT)	Page 43
Low Pressure Indicator Light/Message Is Always On	Page 44
Using Too Much AQ-240 Cleaning Solution or AQ-260 Rinse Agent	Page 45

For additional information, consult your machine's operating manual or contact Aqua Phase.



AQUA PHASE WILL NOT START

Medical Equipment Washing & Decontamination Systems

Possible Causes/Solutions:

- 1) **NO MESSAGE ON LCD DISPLAY SCREEN.**
 - AQ not plugged in
 - GFCI not reset in power cord
 - Circuit breaker tripped
 - Blown fuse in AQ Control Panel Assembly

- 2) **GFCI WILL NOT RESET.**
 - Circuit breaker tripped.
 - Power outage to the area of the building.
 - Defective GFCI
 - Short in AQ system and GFCI doing its job.

- 3) **1 & 2 ARE OK Then check:k:**
 - Front door open
 - Front door out of adjustment/not contacting Front Door Safety Switch
 - Blown fuse in Control Panel Assembly
 - Defective Front Door Safety Switch
 - Defective Start Button



AQUA PHASE WILL NOT FILL WITH WATER

Medical Equipment Washing & Decontamination Systems

Possible Causes/Solutions:

1. **NO POWER TO THE AQUA PHASE:**
 - Connect Aqua Phase to a standard 20 AMP electrical service.
 - Press the reset button located on the GFCI in the Aqua Phase power cord.
2. **WATER SUPPLY IS NOT TURNED ON.**
 - After you are certain the fill and the drain connections are secure, slowly turn-on you water supply.
3. **KINK IN THE WATER HOSE.**
 - Inspect water supply hose to ensure no sharp bends in hose.
4. **FILTER SCREEN / WASHER LOCATED INSIDE "FILL" LINE CONNECTION OF AQUA PHASE IS PLUGGED.**
 - Turn-off water supply. Disconnect water supply hose from Aqua Phase.
 - Inspect condition of Filter screen / washer. If plugged, contact Aqua Phase for replacement. You may temporarily replace the Filter screen/washer with a standard hose washer. However, long-term operation without the Filter screen/washer may cause damage to the Fill Valve.
5. **DEFECTIVE HIGH-LEVEL WATER CONTROL FLOAT SWITCH.**
 - Unplug the Aqua Phase from the power supply.
 - Call the factory.
6. **WATER SUPPLY PRESSURE IS TOO LOW.**
 - Turn-off water supply.
 - Disconnect water supply hose from Aqua Phase.
 - Position end of hose over drain, slowly turn-on your water supply. Note to see if the rate of water appears adequate. If adequate (water will fill a gallon pail in 20 seconds), turn-off water supply, reconnect hose to Aqua Phase, turn-on water supply.
7. **FILL VALVE SOLENOID IS DAMAGED OR HAS DEBRIS STUCK INSIDE IT.**
 - See "Valve Inspection Procedures" located in the Servicing Procedures section of your Aqua Phase's operating manual.
 - Remove the Fill hose from the "Fill" line connection at the Aqua Phase. Check to ensure that the filter screen / washer is in place and intact. If problem remains, call the factory.



AQUA PHASE WILL NOT STOP DRAINING. DRAINING TAKES TOO LONG.

Medical Equipment Washing & Decontamination Systems

Possible Causes/Solutions:

1. PRIMARY FILTER SCREEN DIRTY

- Clean Primary Filter Screen (located in the Water Reservoir inside the Wash Chamber).

2. KINK IN WATER DRAIN HOSE

- Inspect water Drain Hose to ensure no sharp bends in hose.

3. DIRT, DEBRIS, OR HARD WATER DEPOSITS ON LOW-LEVEL FLOAT SWITCH

- Unplug the Aqua Phase from the power supply.
- Locate the Low-Level Float Switch in the Water Reservoir, inside the Wash Chamber.

***Inspect Float Switch to ensure that it is clear of debris and moves freely.*

4. DAMAGED OR DEFECTIVE LOW-LEVEL FLOAT SWITCH

- Unplug the Aqua Phase from the power supply.
- Inspect the Low-Level Float Switch for damage, such as a cracked fitting or binding.
- Replace if damaged—you may order replacement parts by calling your dealer or the factory.

5. DRAIN PUMP FUSE BLOWN.

- Test fuse in Control Panel Assembly.

6. FAULTY DRAIN PUMP



**AQUA PHASE WILL NOT STOP
FILLING. ERROR MESSAGE:
*Fill Time Expired.***

Medical Equipment Washing & Decontamination Systems

Immediately:

- Press the **STOP** button.
- Shut off the water supply.

Possible Causes/Solutions:

1. DOOR NOT PROPERLY CLOSED.

2. FRONT DOOR GASKET DAMAGED OR WORN.

- Inspect Front Door Gasket for wear or damage.
- Replace if necessary—you may order replacement parts by calling your dealer or the factory.

3. EXCESS BUILD-UP OF HARD WATER DEPOSITS ON HIGH-LEVEL FLOAT SWITCH

- Unplug the Aqua Phase from the power supply.
- Locate the High-Level Float Switch in the Water Reservoir, inside the Wash Chamber.

***Inspect High-Level Float Switch to ensure that it is free of debris and moves freely.*

4. DAMAGED OR DEFECTIVE HIGH-LEVEL FLOAT SWITCH

- Unplug the Aqua Phase from the power supply.
- Inspect the High-Level Float Switch for damage, such as a cracked fitting or binding.
- Replace if damaged—you may order replacement parts by calling your dealer or the factory.
- Drain Hose end is submerged in water. (Water is syphoning back into the Aqua Phase).

5. FILL VALVE HAS DEBRIS STUCK IN IT.

- See “Valve Inspection Procedure”.
- Remove the Fill Hose from the fill line connection at the Aqua Phase. Check that the filter screen/washer is in place and intact.
- If problem remains, call the factory for assistance.



ITEMS WASHED HAVE WATER SPOTS OR CLOUDY FILM.

Medical Equipment Washing & Decontamination Systems

Water supplied Aqua Phase is “hard”, a lot of totally dissolved solids.

1. WATER TEMPERATURE BELOW 105°F:

- Check the temperature of the water reaching the Aqua Phase.
- Drain the Aqua Phase.
- Press the “**START**” button. Allow the Aqua Phase to fill.
- As soon as Aqua Phase begins to pump, press the “**STOP**” button.
- Open the front door, place a thermometer in the Water Reservoir to check the water temperature. Water temperature should be between 105°-130°.
- AQ-260 Rinse-Aid Solution requires a water temperature at or above 105°

2. THE WATER SUPPLY TO THE AQUA PHASE IS “HARD” WATER.

- The AQ-240 Cleaning Solution, in conjunction with the spray nozzles are in effect cleaning the water, and taking the hard water particles out of suspension.
- A Water Fill Assembly (5-10 Micron Cartridge) from Aqua Phase factory, installed at the Fill Line may correct this pending the water contaminants.
- It may be correctable, pending the pH of the water, and the totally dissolved solids of the water to alter the injection rate of the AQ-240 Cleaning Solution to reduce the amount of solids being taken out of suspension.

3. RINSE-AID SOLUTION CONTAINER EMPTY

- Check the level of rinse-aid solution, refill if necessary. The chemical solutions are located inside the Mechanical Cabinet at the rear of the Aqua Phase.

4. RINSE CHEMICAL INJECTOR HOSE OR FITTINGS ARE WORN.

- Inspect chemical hoses for cracks and inspect chemical hose fittings for cracks or if loose.
- Replace if damaged—you may order replacement parts by calling your dealer or the factory.

Notes:

The solution injection rates are preset at the factory for the worst possible water condition expected to be found.

If spotting or clouding is present only on the first item washed, it is possible that you will need to run a “warm-up cycle” with Aqua Phase. Run a “3-minute” wash cycle with the Wash Chamber empty to allow the Wash Chamber to be warmed-up prior to commencing normal washing operations.

If problem persists, call the factory for assistance.



ITEMS NOT CLEANED PROPERLY.

Medical Equipment Washing & Decontamination Systems

Possible Causes/Solutions:

1. ARE YOU USING AQUA PHASE BRAND DETERGENT & RINSE SOLUTIONS?

- Aqua Phase chemicals are specifically designed for use in the Aqua Phase systems. They are formulated to clean equipment virtually spot-free and speed drying time. *You may order cleaning chemicals by calling your dealer or the factory.*

2. DETERGENT SOLUTION CONTAINER IS EMPTY.

- Check the level of detergent and refill if necessary.
The chemical solutions are located inside the Chemical Cabinet.

3. FILTER SCREEN(S) NOT CLEAN.

- Clean Primary Filter Screen (Primary Filter Screen is located in the bottom of the Water Reservoir located inside the Wash Chamber).

4. SPRAY NOZZLES CLOGGED

- Virtually inspect spray nozzles for debris.
- For spray nozzles that are clogged, note the position of the spray nozzle's relative spray angles.

5. CHEMICAL PUMP HOSES ARE WORN.

6. LONGER WASH CYCLE REQUIRED.

- Set the wash cycle time to **"7 MINUTES"** or to the longest time cycle available.
- Press the "Start" button, and allow Aqua Phase to run a complete cycle.

7. WATER TEMPERATURE TOO LOW.

- Check the temperature of the water reaching the Aqua Phase.
- Drain the Aqua Phase.
- Press the **"START"** button. Allow the Aqua Phase to fill.
- As soon as Aqua Phase begins to pump, press the **"STOP"** button.
- Open the front door, place a thermometer in the water reservoir to check the water temperature. The recommended water temperature is 115-140°. (105° is functional).



"GROWLING" NOISE (pump cavitation) THE VOLUME OF SPRAY IS LOW.

Medical Equipment Washing & Decontamination Systems

The “growling” noise is caused by air getting into the pump impeller. Growling noise is normally heard at the end of the drain cycle. If you hear it continually, you have one of the following problems.

Possible Causes/Solutions:

1. MACHINE NOT IN LEVEL OPERAING POSISTION

- Ensure that the Aqua Phase unit is level.

2. PRIMARY OR SECONDARY FILTER SCREEN(S) NOT CLEAN

- Clean Filter Screen(s) (filter screens located in the bottom of the water reservoir which is located inside the Wash Chamber)

3. HIGH-LEVEL FLOAT SWITCH COVERED WITH DEBRIS

- Unplug the Aqua Phase from the power supply.
- Locate the high-level float switch in the Mechanical Cabinet, of the Water Reservoir, inside the Wash Chamber. Inspect for debris covering the probe, remove debris if present.

4. CHEMICAL INJECTOR HOSE OR FITTINGS ARE CRACKED OR LOOSE.

- Inspect Chemical Hoses for cracks and inspect Chemical Hose Fittings for cracks or if loose.
- Replace if damaged – *you may order replacement parts by calling your dealer or the factory.*

5. CHEMICAL PUMP HOSE CRACKED

- Inspect hoses located inside the chemical pumps for cracks.
- Replace if damaged – *you may order replacement parts by calling your dealer or the factory.*

6. PUMP IMPELLER CLOGGED WITH DEBRIS

- See “Pump Impeller Inspection Procedures” located in the Servicing Procedures Guide section of your Aqua Phase’s operating manual. It is recommended that you contact the factory before attempting to clear debris from the pump impeller.

7. FOAM IN WATER RESERVOIR AREA – caused by something on the item washed use of a foaming detergent or rinse-aid. Foam may affect certain sensors that control the filling and draining of water.

- Press the “**Stop**” button and wait a few minutes until the foam dissipates.
- Remove hose from all cleaning supply bottles in the rear of the Aqua Phase.
- Press the “**Start**” button and allow Aqua Phase to do a complete cycle.
- Repeat the preceding steps until Aqua Phase starts draining normally.



"LOW PRESSURE INDICATOR LIGHT/MESSAGE IS ALWAYS ON

Medical Equipment Washing & Decontamination Systems

Possible Causes/Solutions:

The "Low Pressure" indicator light is to inform you that your Aqua Phase may not be spraying an adequate amount of water to achieve proper cleaning.

1. FILTER SCREEN(S) NOT CLEAN

- Clean filter screen(s)
- Clean Primary Filter Screen (Primary Filter Screen is located in the bottom of the water reservoir, located inside of the Wash Chamber).
- See also Making "Growling" Noise

2. DETECTIVE PRESSURE SENSOR.

- Replace—you may order replacement parts by calling your dealer or the factory.

3. PUMP IMPELLER CLOGGED WITH DEBRIS

- See "**Pump Impeller Inspection Procedures**" located in the *Servicing Procedures Guide* section of your Aqua Phase's operating manual. It is recommended that you contact the factory before servicing the pump impeller.



USING TOO MUCH AQ-240 CLEANING SOLUTION OR AQ-260 RINSE AGENT.

Medical Equipment Washing & Decontamination Systems

Possible Causes/Solutions:

1. CHEMICAL PUMP HOSE WORN.

- Inspect hoses located inside the chemical pumps for cracks
- Replace if damaged—you may order replacement parts by calling your dealer or the factory.

2. CHEMICAL PUMP ROLLER ASSEMBLY IS WORN.

- Inspect chemical pump hose roller and determine if chemical pump hose is being fully pinched. If not, replace both the chemical hose and the roller assembly.



AQUA PHASE CHEMICALS & DESCRIPTIONS

Medical Equipment Washing & Decontamination Systems

AQ-240 Cleaning Solution

4 gallons/case

The Cleaning Solution was developed and formulated by Aqua Phase, specifically for use in the Aqua Phase systems. The AQ-240 is an industrial grade cleaner, with an elevated pH, to breakdown the fluids, proteins, and carbohydrate commonly found on medical equipment. In conjunction with the AQ-240 breakdown processes, and the spray impact from the Aqua Phase system, an excellent job is done in the removal of the gross soil contaminants. We can't put on the bottle, but we can prove the effectiveness of an Aqua Phase system with the use of AQ-240 against CDIF as proven by an independent, third party, testing laboratory.

AQ-260 Rinse Aid Solution

4 gallons/ case

The Rinse Aid Solution was developed and formulated by Aqua Phase, specifically for use in the Aqua Phase Systems. The Aqua Phase AQ-260 was one of the first rinse-agents ever developed to activate at 105° (F). When activated, the AQ-260 reduces the surface tension of any residual water droplets on your medical equipment which eliminates water spots. The reduced surface tension of the water also aids in the process of flash evaporation resulting in air drying of equipment surfaces in 2-3 minutes.

AQ-280 Rust Inhibitor Rinse Solution

4 gallons / case

The Rust Inhibitor can be used periodically, or all the time in place of the AQ-240 Rinse Aid Solution. AQ-280 is a reformulation of a fluid used by US Steel Mills that protected raw steel after it came out of the forges to prevent oxidation (rusting) of the unprotected metal surfaces. The reformulation allows for a micro thin coating to the surfaces, without a cloudy, or grease film residue being left on medical equipment. The AQ-280 inhibits the oxidation process on existing equipment, and provides a protection to surface of uncoated metals that the original equipment manufacturer may not have provided.

AQ-725 Deliming Solution

12 quarts / case

When hard water is supplied to the Aqua Phase system, the periodic use of the AQ-725 is a great preventative maintenance measure. The AQ-725 is an industrial grade solution, similar to those used to clean the drum of a cement mixing truck. The AQ-725 breaks down the deposits that may build up on the Aqua Phase chamber walls due to the hard water that is supplied to the Aqua Phase system. It is easy-to-use, pre-measured, can be used weekly or as needed, and the instructions are printed on the quart bottle.

AQ-128 HDQ Neutral Disinfectant

4 gallons / case

The HDQ Neutral is a quart based disinfectant suitable for the disinfection of hard, non-porous environmental surfaces. Use of the AQ-128 in Aqua Phase does not require a post rinse like some disinfectants. A review of the bottle labeling is required for a complete listing of organisms that HDQ Neutral is effective against. A few included are: MRSA, VRE, HBV, HCV, HIV, and certain virucidal and fungicidal claims. HDQ has a 1 ounce per gallon dilution rate.

AQ-130 Germicidal PD-128 Disinfectant

4 gallons /case

The Spartan Chemical, PD-128 has claims of a Tuberculocidal grade/type of disinfectant. Use of the AQ-130 (Spartan PD-128) does not require a post rinse, has a dilution rate of 1 ounce per gallon, and a kill claim against HIV of 1 minute contact time. Other claims include: fungicidal, staphylocidal, pseudomonacidal, and virucidal.

PRE-MEASURED - EASY & READY TO GO!

AQUA PHASE SOLUTIONS ARE PLACED IN THE UTILITY PANEL OF YOUR AQUA PHASE UNIT



AQ-240 Cleaning Solution Safety Data Sheet

Medical Equipment Washing & Decontamination Systems



NATIONAL PURITY, LLC.
6840 SHINGLE CREEK PKWY, STE 23
BROOKLYN CENTER, MN 55430
(612) 672-0022

SAFETY DATA SHEET

1. Product and Company Identification

Product Name	AQUAPHASE AQ-240 CLEANING SOLUTION
Product Number	P678
Product Type	Mixture
Product Use	Detergent designed specifically for use in the Aquaphase Wheelchair Washing Machine.
Manufacturer/Supplier	National Purity, LLC. 6840 Shingle Creek Parkway, Suite #23 Brooklyn Center, MN 55430
Company Contact	612-672-0022
Emergency Telephone Number	1-800-255-3924

2. Hazards Identification

GHS Classification in accordance with 29 CFR 1910 OSHA HCS

Acute toxicity, Oral (Category 3) H301
Skin corrosion/irritation, (Category 1B) H314
Eye damage/irritation, (Category 1) H318
Acute toxicity, inhalation (Category 4) H332
Acute aquatic toxicity, (Acute 2) H401
Chronic aquatic toxicity, (Chronic 3) H412

GHS Label elements, including precautionary statements

Pictogram



Signal word

Danger

Hazard Statements

H301 Harmful if swallowed.
H314 Causes severe skin burns and eye damage.
H318 Causes serious eye damage
H332 Harmful if inhaled.
H401 Toxic to aquatic life
H412 Harmful to aquatic life with long lasting effects.

Precautionary Statements

Prevention

P280 Wear protective gloves/protective clothing/eye protection/face protection.
P260 Do not breath mist, vapors, or spray.
P264 Wash hand and exposed skin thoroughly after handling.
P270 Do not eat, drink or smoke when using this product.
P271 Use only outdoors or in a well ventilated area.
P273 Avoid release to the environment.



AQ-240 Cleaning Solution Safety Data Sheets

Medical Equipment Washing & Decontamination Systems



NATIONAL PURITY, L.L.C.
6840 SHINGLE CREED PKWY, STE 23
BROOKLYN CENTER, MN 55430
(612) 672-0022

Response

P301+P310+P330

IF SWALLOWED, immediately call a POISON CENTER/doctor. DO NOT INDUCE VOMITING. Rinse mouth with water. Never give anything to an unconscious person.

P303+361+P353+P363

IF ON SKIN, Immediately take off all contaminated clothing. Rinse skin with water or shower if appropriate. Wash contaminated clothing before reuse.

P305+P351+P338

IF IN EYES, rinse cautiously for several minutes. Remove contact lenses if present and easy to do so. Continue rinsing.

P310

Immediately call a POISON CENTER/doctor for medical assistance.

P304+P340+P312

IF INHALED: remove person to fresh air and keep comfortable for breathing. Call a POISON CENTER/doctor if feeling unwell.

Storage/Disposal

P405

Store locked up.

P501

Dispose of contents/container in accordance with local, state and federal regulations.

3. Composition/Information on Ingredients

The criteria for listing components in this section are: Ingredients that meet the criteria for carcinogenic, toxic to reproduction, or specific target organ toxicity and components otherwise considered hazardous according to OSHA which exceed the cut off limits for SDS specified by the criteria for mixtures are listed. Non hazardous components are not listed. This is not a composition disclosure. Exact percentages are considered proprietary and a trade secret.

Hazardous Components	CAS#	Classification	%
Potassium hydroxide	1310-58-3	H301, H314, H318, H402, H412	10-20%
Sodium silicate	1344-09-8	H302, H315, H320, H333, H402, H412	10-15%
Sodium gluconate	527-07-1	H316, H320	2-8%

4. First Aid Measures

Description of First Aid Procedures

General Advise

Consult a physician. Show this SDS to the doctor.

In Case of Eye Contact

Flush with cool running water for 15 minutes. Remove contact lenses if possible. Get immediate medical attention.

In Case of Skin Contact If Ingested

Flush with cool water. If irritation occurs, get medical attention. Rinse mouth with water. **Do not induce vomiting.** Obtain medical attention. Never give anything by mouth to an unconscious person.

If Inhaled

Move person to fresh air. If breathing difficulty persists, consult a physician. Symptoms may be delayed.

Notes to Physician

General advice

Seek medical attention if feeling unwell. Show the SDS to the physician in attendance.

5. Fire-fighting Measures

Flammable properties

Not flammable

Extinguishing media

Use materials designed for source of fire. Treat as an alkaline material.

Protection of firefighters

Firefighters should wear protective clothing including self contained breathing apparatus.

Hazardous combustion products

May include and not limited to oxides of carbon, and nitrogen, and sulfur.

Unusual Fire, Explosion hazards

Containers may melt or rupture from heat of fire. May form combustible mixtures with air when heated.

6. Accidental Release Measures

Personal precautions

Keep unnecessary personal away. Do not touch or walk through spilled material. Do not touch damaged containers or spilled containers unless wearing protective Clothing.



AQ-240 Cleaning Solution Safety Data Sheets

Medical Equipment Washing & Decontamination Systems



NATIONAL PURITY, LLC.
6840 SHINGLE CREED PKWY, STE 23
BROOKLYN CENTER, MN 55430
(612) 672-0022

Methods for containment Methods for cleaning up

Stop leak if you can do so without risk. Prevent entry into waterways, sewers. Before attempting clean up, refer to hazard data given above. Small spills may be mopped up and rinsed. Large spills may be absorbed with non reactive absorbent and placed in suitable, covered, labeled containers. Rinse area with water. Never return spill to original container for reuse.

Environmental precautions

Keep out of waterways. Dispose of contents/containers in accordance with local, state, and federal regulations.

7. Handling and Storage

Precautions for Safe Handling

Use good industrial hygiene practices when handling this material. Avoid contact with skin and eyes. Avoid inhalation of mists or vapors. Wash contaminated clothing before reuse.

Conditions for Safe Storage

Keep container closed when not in use. Keep out of reach of children. Store in cool, well ventilated, dry place, locked up.

8. Exposure Controls and Personal Protection

Exposure Limits

Ingredients

Ingredients	CAS#	OSHA PEL	ACGIH TLV
Potassium hydroxide	1310-58-3	Not available	2mg/m ³ TLV
Sodium silicate	1344-09-8	Not available	Not available
Sodium gluconate	527-07-1	Not available	5 mg/m ³ TLV

Engineering controls

Local exhaust ventilation recommended.

Personal protective equipment

Eye/Face protection

Wear safety glasses with side shields if splash conditions exist. Have eye wash water and shower facilities available in work area.

Hand protection

Wear safety gloves.

Skin and body

As required by employer code.

Respiratory protection

Use a NIOSH approved respirator when exposure guidelines are exceeded.

General hygiene considerations

Handle in accordance with good industrial hygiene practices. Do not eat or drink when using product. Wash hands well before breaks and immediately after handling the product.

9. Physical and Chemical Properties

Information on basic physical and chemical properties

Appearance/form	Clear liquid
Color	Amber
Odor	Odorless
Odor threshold	Not established
pH	14 (concentrate)
Melting/freezing point	Not established
Initial Boiling point	≈212° F. (100° C.)
Flash point	None
Evaporation rate	Not established
Flammability	Not flammable
Upper/lower flammability or Explosive limits	Not applicable
Vapor pressure	Not established
Vapor density	Not established
Specific gravity/density	1.344
Vapor density	Not established
Solubility in water	Complete
VOC	< 1.0%
% Volatile	Approx. 77%

Other Safety Information



AQ-240 Cleaning Solution Safety Data Sheets

Medical Equipment Washing & Decontamination Systems



NATIONAL PURITY, LLC.
6840 SHINGLE CREED PKWY, STE 23
BROOKLYN CENTER, MN 55430
(612) 672-0022

10. Stability and Reactivity

Reactivity	No data available
Chemical Stability	Stable under normal storage conditions.
Hazardous reactions	None known.
Conditions to avoid	Do not mix with other chemicals. Keep away from sources of heat.
Incompatible materials	Strong acids, alkalis, strong oxidizing agents. Contact with metals like Aluminum, tin, and zinc liberates hydrogen gas. Can react vigorously with halogens.
Hazardous decomposition products	May include but not limited to oxides of carbon, and nitrogen.
Hazardous polymerization	Will not occur.

11. Toxicological Information

Ingredients	LC50
Potassium hydroxide	Not available
Sodium silicate	Not available
Sodium gluconate	
Ingredients	LD50
Potassium hydroxide	Not available
Sodium silicate	1500-3200 mg/kg (Oral-rats)
Sodium gluconate	> 2000 mg/kg (Oral-rat)
Effects of acute exposure	
Eye	Will cause severe eye damage.
Skin	Will cause severe skin burns.
Ingestion	Harmful if swallowed. May cause corrosive damage to mouth, throat and stomach.
Inhalation	May cause irritation of nose and throat.
Sensitization	No data available.
Chronic effects of short and long Term exposure	Prolonged exposure to skin may cause drying, defatting and irritation.
Carcinogenicity	Does not contain ingredients considered carcinogenic by NTP, IARC, or OSHA.
Mutagenicity	No data available.
Reproductive effects	No data available.
Teratogenicity	No data available.

12. Ecological Information

Eco-toxicity	Ecological effects for this product have not been analyzed. However, if spilled this product and any contaminated soil may be toxic to aquatic life and have long lasting effects.
Environmental effects	No data available.
Aquatic toxicity	The high pH of this product is acutely harmful to aquatic life.
Potassium hydroxide	No data available
Sodium silicate	LC50 Daphnia magna: 246 mg/l 96 hours
	LC50 Fish (Gambusia affinis): 2320 mg/l 96 hours
	LC50 Fish: > 1000 mg/l 96 hour (predicted)
Sodium gluconate	LC50 Daphnia magna: > 1000 mg/l 96 hour (Predicted)
Persistence and Degradability	No data available.
Bioaccumulation/accumulation	No data available.
Partition coefficient	No data available.
Mobility in environmental media	No data available.
Chemical fate information	No data available.
Other adverse effects	No data available.



AQ-240 Cleaning Solution Safety Data Sheets

Medical Equipment Washing & Decontamination Systems



NATIONAL PURITY, I.L.C.
6840 SHINGLE CREED PKWY, STE 23
BROOKLYN CENTER, MN 55430
(612) 672-0022

16. Other Information

HMIS RATING HMIS Legend

Severe	4
Serious	3
Moderate	2
Slight	1
Minimal	0

Health	3
Flammability	0
Reactivity	1
Personal Protection	B

Disclaimer

To the best of our knowledge, the information included herein is accurate. However, neither the above named supplier nor any of its subsidiaries assume any liability whatsoever for the accuracy or completeness of the information contained herein. Final determination of the suitability of any material is the responsibility of the user. All materials may present unknown hazards and should be used with caution. Although certain hazards are described herein, we cannot guarantee that these are the only hazards that exist.

Issue date
Supersedes date
Reason for update
Expiration date

March 5, 2015
Previous issues
Conform to GHS OSHA HCS 2012
March 5, 2018



AQ-240 Cleaning Solution Safety Data Sheets

Medical Equipment Washing & Decontamination Systems

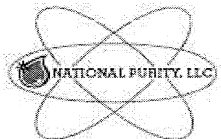

NATIONAL PURITY, LLC.
6840 SHINGLE CREED PKWY, STE 23
BROOKLYN CENTER, MN 55430
(612) 672-0022

13. Disposal Considerations

Waste codes	Not Available
Disposal instructions	Dispose in accordance with local, state, and federal regulations.
Wastes from residues/unused product	Containerize. Rinse area with water. Keep out of storm sewer/waterways.
Contaminated packaging	Dispose in accordance with all applicable regulations.

14. Transport Information

Basic shipping requirements:	
Proper shipping name	Corrosive liquid, n.o.s. (Contains potassium hydroxide, sodium silicate), 8, UN1760, PG II
Hazard class	Corrosive liquid, 8
UN number	UN1760
Packing group	PG II
Special provisions	Not applicable

15. Regulatory Information

U.S federal regulations	This product has been classified in accordance with the Occupational Safety and Health Administration hazard criteria and the SDS contains all of the information required by OSHA. HCS 2012	
TSCA	All ingredients are listed on the Toxic Substances Control Act or are exempt from listing.	
Cercla SuperFund 40CFR117.302 Potassium hydroxide	This product contains a material with a Reportable Quantity (RQ) RQ= 25,000 Lbs.	
SARA Title III Section 311&312 SARA Title III Section 313	Immediate (Acute) Health Hazard Product does not contain substances on the list of Toxic Chemicals per 40CFR372:	
States Right to Know	Reportable chemicals: Potassium hydroxide,	
California Proposition 65	This product does not contain chemicals known to the state of California to cause cancer.	
Inventory Status	Inventory Name	On Inventory (Yes/No)*
Countries		
U.S.	CIL	Yes
Canada	DSL	Yes

- A "Yes" indicates that all of the components of this product comply with the inventory requirements administered by the governing country(s) listed.



AQ-260 Rinse Solution Safety Data Sheets

Medical Equipment Washing & Decontamination Systems



NATIONAL PURITY, LLC.
6840 SHINGLE CREEK PKWY, STE 23
BROOKLYN CENTER, MN 55430
(612) 672-0022

SAFETY DATA SHEET

1. Product and Company Identification

Product Name	AQ-260 AQUAPHASE RINSE AGENT
Product Number	P153
Product Type	Mixture
Product Use	Commercial dishwashing additive for preventing spots on dinnerware.
Manufacturer/Supplier	National Purity, LLC. 6840 Shingle Creek Parkway, Suite #23 Brooklyn Center, MN 55430
Company Contact	612-672-0022
Emergency Telephone Number	1-800-255-3924

2. Hazards Identification

GHS Classification in accordance with 29 CFR 1910 OSHA HCS

Acute toxicity, Oral (Category 5) H303,
Eye damage/irritation, (Category 2B) H320
Skin corrosion/irritation (Category 3) H316
Acute aquatic toxicity, (Category 2) H401

GHS Label elements, including precautionary statements

Pictogram	None required
Signal word	Warning
Hazard Statements	
H303	May be harmful if swallowed.
H320	Causes eye irritation.
H316	May cause mild skin irritation
H401	Toxic to aquatic life.
Precautionary Statements	
Prevention	
P264	Wash and rinse hands thoroughly. Avoid hand contact with eyes while washing hands.
P273	Avoid release to the environment.
Response	
P312	IF SWALLOWED, call a POISON CENTER/doctor if feeling unwell.
P332+P313	If skin irritation occurs, get medical attention.
P305+P351+P337+P313	IF IN EYES, rinse cautiously for several minutes. Remove contact lenses if present. Continue rinsing. If eye irritation persists, Get medical advice and attention.
Storage/Disposal	
P501	Dispose of contents/container in accordance with local/regional/federal regulations.



AQ-260 Rinse Solution Safety Data Sheets

Medical Equipment Washing & Decontamination Systems



NATIONAL PURITY, LLC.
6840 SHINGLE CREED PKWY, STE 23
BROOKLYN CENTER, MN 55430
(612) 672-0022

3. Composition/Information on Ingredients

The criteria for listing components in this section are: Ingredients that meet the criteria for carcinogenic, toxic to reproduction, or specific target organ toxicity and components otherwise considered hazardous according to OSHA which exceed the cut off limits for SDS specified by the criteria for mixtures are listed. Non hazardous components are not listed. This is not a composition disclosure. Exact percentages are considered proprietary and a trade secret.

Hazardous Components	CAS#	Classification	%
Alcohols, C8-C10, ethoxylated propoxylated	68603-25-8	H303, H320	20-40%
Sodium alkyl naphthalene sulfonate	Proprietary	H303, H316, H320, H401	1-5%

4. First Aid Measures

Description of First Aid Procedures

General Advice	Consult a physician. Show this SDS to the doctor.
In Case of Eye Contact	Flush with cool running water for 15 minutes. Remove contact lenses if present. If irritation occurs, get medical attention.
In Case of Skin Contact	Flush with cool water. If irritation occurs, get medical attention.
If Ingested	Rinse mouth with water. Do not induce vomiting. Obtain medical attention if feeling unwell.
If Inhaled	Move person to fresh air. If breathing difficulty occurs, consult a physician.
Notes to Physician	Symptoms may be delayed.
General advice	Seek medical attention if feeling unwell. Show the SDS to the physician in attendance.

5. Fire-fighting Measures

Flammable properties	Not flammable below boiling points
Extinguishing media	Water spray or fog, carbon dioxide, foam or dry chemicals.
Protection of firefighters	Firefighters should wear protective clothing including self contained breathing apparatus
Hazardous combustion products	May include and not limited to oxides of carbon.
Unusual Fire, Explosion hazards	Evacuate the area promptly. Cool containers exposed to heat. Containers may melt or rupture from heat of fire.

6. Accidental Release Measures

Personal precautions	Keep unnecessary personal away. Do not touch or walk through spilled material. Avoid contact with skin, eyes and clothing.
Methods for containment	Stop leak if you can do so without risk. Prevent entry into waterways, sewers. Eliminate all ignition sources (no smoking, sparks, or flames) in area.
Methods for cleaning up	Before attempting clean up, refer to hazard data given above. Small spills, may be absorbed with non reactive absorbent and placed in suitable container for disposal. Large spills, dike area to prevent from spreading. Absorb with non reactive absorbent and place in suitable, covered, and labeled container. Rinse area with water. Never return spill to original container.
Environmental precautions	Avoid spills. Keep out of waterways.

7. Handling and Storage

Precautions for Safe Handling	Use good industrial hygiene practices when handling this material. Use in well ventilated area. Do not breath vapors or spray. Avoid prolonged or repeated contact with skin. Avoid release to the environment.
Conditions for Safe Storage	Keep container closed when not in use. Store at temperatures below 120° F. (50° C.)



AQ-260 Rinse Solution Safety Data Sheets

Medical Equipment Washing & Decontamination Systems



NATIONAL PURITY, LLC.
6840 SHINGLE CREED PKWY, STE 23
BROOKLYN CENTER, MN 55430
(612) 672-0022

8. Exposure Controls and Personal Protection

Exposure Limits			
Ingredients	CAS#	OSHA PEL	ACGIH TLV
Alcohols, C8-C10, ethoxylated propoxylated	68603-25-8	Not available	Not available
Sodium alkyl naphthalene sulfonate	Proprietary	Not available	Not available
Engineering controls	General ventilation normally adequate.		
Personal protective equipment			
Eye/Face protection	None usually required under normal use conditions. Wear safety glasses with side shields when splash conditions exist.		
Hand protection	None usually required.		
Skin and body	Generally not required.		
Respiratory protection	Generally not required.		
General hygiene considerations	Handle in accordance with good industrial hygiene practices.		

9. Physical and Chemical Properties

Information on basic physical and chemical properties	
Appearance/form	Clear liquid
Color	Blue
Odor	Mild odor
Odor threshold	Not established
pH	3.0-3.2 (Concentrate)
Melting/freezing point	Not established
Initial Boiling point	Not established
Flash point	> 200° F. (93° C.)
Evaporation rate	< 1 (butyl acetate = 1)
Flammability	Not flammable
Upper/lower flammability or explosive limits	Not applicable
Vapor pressure	Not established
Vapor density	Not established
Specific gravity/density	1.045
Solubility in water	Complete
VOC	< 1%
% Volatile	Approx. 77%
Other Safety Information	

10. Stability and Reactivity

Reactivity	Not reactive under normal use and storage.
Chemical Stability	Stable under normal storage conditions.
Hazardous reactions	None known.
Conditions to avoid	Do not mix with other chemicals.
Incompatible materials	Strong acids, strong oxidizing agents.
Hazardous decomposition products	May include but not limited to oxides of carbon.
Hazardous polymerization	Will not occur.



AQ-260 Rinse Solution Safety Data Sheet

Medical Equipment Washing & Decontamination Systems



NATIONAL PURITY, LLC.
6840 SHINGLE CREED PKWY, STE 23
BROOKLYN CENTER, MN 55430
(612) 672-0022

11. Toxicological Information

Ingredients Alcohols, C8-C10, ethoxylated propoxylated Sodium alkynapthalene sulfonate	LC50 Not available Not available
Ingredients Alcohols, C8-C10, ethoxylated propoxylated Sodium alkynapthalene sulfonate	LD50 Not available Not available
Effects of Acute Exposure- Eye Skin Ingestion Inhalation Sensitization Chronic effects of short and long Term exposure Carcinogenicity	Causes eye irritation. May cause mild skin irritation. May be harmful if swallowed. May cause irritation of gastrointestinal tract. No data available Not known to be a sensitizer. Prolonged exposure to skin may cause drying, defatting and irritation. Intentionally added ingredients are not considered carcinogenic by NTP, IARC or OSHA. Product may contain trace amounts (< 0.0003%) of ethylene oxide (CAS#75-21-8) a suspected human carcinogen and (<0.0006%) of propylene oxide (CAS#75-56-9) which is anticipated to be a human carcinogen.
Mutagenicity: Reproductive effects: Teratogenicity:	No data available. No data available. No data available.

12. Ecological Information

Eco-toxicity Environmental effects: Aquatic toxicity: Persistence and Degradability: Bioaccumulation/accumulation: Partition coefficient: Mobility in environmental media: Chemical fate information: Other adverse effects:	Ecological effects for this product have not been analyzed. However, if spilled this products ingredients are harmful to aquatic life. No data available. Although no data is available, the ingredients of this products are expected to be moderately toxic to aquatic life. No data available. No data available. No data available. No data available. No data available. No data available.
---	--

13. Disposal Considerations

Waste codes Disposal instructions Wastes from residues/unused product Contaminated packaging	Not Available Dispose in accordance with local, state, and federal regulations. Containerize. Rinse area with water. Keep out of storm sewer/waterways. Dispose in accordance with all applicable regulations.
---	---

14. Transport Information

Basic shipping requirements:	Not DOT regulated
-------------------------------------	-------------------



AQ-260 Rinse Solution Safety Data Sheets

Medical Equipment Washing & Decontamination Systems



NATIONAL PURITY, LLC.
6840 SHINGLE CREEK PKWY, STE 23
BROOKLYN CENTER, MN 55430
(612) 672-0022

15. Regulatory Information

U.S federal regulations	This product has been classified in accordance with the Occupational Safety and Health Administration hazard criteria and the SDS contains all of the information required by OSHA. HCS 2012.	
TSCA	All ingredients are listed on the Toxic Substances Control Act or are exempt from listing.	
SARA Title III Section 311&312 SARA Title III Section 313	Immediate (Acute) Health Hazard. This product does not contain any chemical components with known CAS#'s that exceed the threshold (De Minimis) reporting levels established by SARA Title III, Section 313.	
California Proposition 65	This product does contain chemicals known to the state of California to cause cancer. Product may contain trace amounts (< 0.0003%) of ethylene oxide (CAS#75-21-8) a suspected human carcinogen and (<0.0006%) of propylene oxide (CAS#75-56-9) which is anticipated to be a human carcinogen.	
States Right To Know Components	Reportable chemicals: None known.	
Inventory Status		
Countries	Inventory Name	On Inventory (Yes/No)*
U.S.	CIL	Yes
Canada	DSL	Yes
<ul style="list-style-type: none"> A "Yes" indicates that all of the components of this product comply with the inventory requirements administered by the governing country(s) listed. 		

16. Other Information

HMIS RATING

HMIS Legend

Severe	4
Serious	3
Moderate	2
Slight	1
Minimal	0

Health	1
Flammability	0
Reactivity	0
Personal Protection	0

Disclaimer

To the best of our knowledge, the information included herein is accurate. However, neither the above named supplier nor any of its subsidiaries assume any liability whatsoever for the accuracy or completeness of the information contained herein. Final determination of the suitability of any material is the responsibility of the user. All materials may present unknown hazards and should be used with caution. Although certain hazards are described herein, we cannot guarantee that these are the only hazards that exist.

Issue date
Supersedes date
Reason for update
Expiration date

March 5, 2015
Previous issues
Conform to GHS OSHA HCS 2012
March 5, 2018

3/5/2015

Page 5 of 5



AQ-280 Rust Inhibitor Safety Data Sheets

Medical Equipment Washing & Decontamination Systems



NATIONAL PURITY, LLC.
6840 SHINGLE CREEK PKWY, STE 23
BROOKLYN CENTER, MN 55430
(612) 672-0022

SAFETY DATA SHEET

1. Product and Company Identification

Product Name	AQUAPHASE AQ-280 RUST INHIBITOR
Product Number	P082
Product Type	Mixture
Product Use	Underbody rust inhibitor for vehicles.
Manufacturer/Supplier	National Purity, LLC. 6840 Shingle Creek Parkway, Suite #23 Brooklyn Center, MN 55430
Company Contact	612-672-0022
Emergency Telephone Number	1-800-255-3924

2. Hazards Identification

GHS Classification in accordance with 29 CFR 1910 OSHA HCS

Flammable liquid, (Category 3) H226
Acute toxicity, Oral (Category 5) H303
Skin corrosion/irritation, (Category 1) H314,
Serious eye damage/eye irritation, (Category 1) H318
Specific organ toxicity (Category 1), H370

GHS Label elements, including precautionary statements

Pictogram



Signal word

Danger

Hazard Statements

H226 Flammable liquid and vapor.
H303 May be harmful if swallowed.
H314 Causes severe skin burns and eye damage.
H370 Risk of serious damage to the lungs by inhalation.

Precautionary Statements

Prevention

P210 Keep away from heat, hot surfaces, sparks, open flames, ignition sources. No smoking.
P233 Keep container tightly closed.
P243 Take action to prevent static discharges.
P261 Avoid breathing mists, vapors, or spray.
P264 Wash hands and exposed skin thoroughly after handling.
P280 Wear protective gloves/protective clothing/eye protection/face protection.
P270 Do not eat, drink or smoke when using this product.
P271 Use only outdoors or in a well ventilated area.

Response

P370+P378 In case of fire, use procedures appropriate for the primary source of fire.
P303+361+P353+P363 IF ON SKIN, immediately take off all contaminated clothing. Rinse skin with water or shower if appropriate. Wash contaminated clothing before reuse.



AQ-280 Rust Inhibitor Safety Data Sheets

Medical Equipment Washing & Decontamination Systems

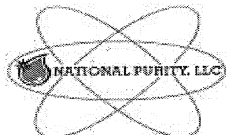

NATIONAL PURITY, LLC.
6840 SHINGLE CREED PKWY, STE 23
BROOKLYN CENTER, MN 55430
(612) 672-0022

P301++P330+P331
P305+P351+P338

P310
P304+P340
P310
P308+P311

Storage/Disposal
P403+P233+P235
P405
P501

IF SWALLOWED: Rinse mouth. DO NOT INDUCE VOMITING.
IF IN EYES, rinse cautiously for several minutes. Remove contact lenses if present. Continue rinsing.
Immediately call a POISON CENTER/doctor.
IF INHALED: remove person to fresh air and keep comfortable for breathing.
Immediately call a POISON CENTER/doctor.
If exposed or concerned about inhalation, call a POISON CENTER/doctor.

Store in a well ventilated place. Keep cool. Keep container tightly closed.
Store locked up.
Dispose of contents/container in accordance with local, state and federal regulations.

3. Composition/Information on Ingredients

The criteria for listing components in this section are: Ingredients that meet the criteria for carcinogenic, toxic to reproduction, or specific target organ toxicity and components otherwise considered hazardous according to OSHA which exceed the cut off limits for SDS specified by the criteria for mixtures are listed. Non hazardous components are not listed. This is not a composition disclosure. Exact percentages are considered proprietary and a trade secret.

Hazardous Components	CAS#	Classification	%
1-Propanamine, 3-(isodecyloxy)-,acetate	28701-67-9	H302, H314, H370	20-30%
Ethylene glycol monobutyl ether	111-76-2	H227, H316, H320	1-10%
Isopropyl alcohol	67-63-0	H225, H319, H336	1-10%

4. First Aid Measures

Description of First Aid Procedures

General Advice

Consult a physician. Show this SDS to the doctor.

In Case of Eye Contact

Flush with cool running water for 15 minutes. Remove contact lenses if possible. Get immediate medical attention.

In Case of Skin Contact If Ingested

Flush with cool water. If irritation occurs, get medical attention.
Rinse mouth. **Do not induce vomiting.** Obtain immediate medical attention. Never give anything by mouth to an unconscious person.
Move person to fresh air. If breathing difficulty persists, consult a physician.
Symptoms may be delayed.

If Inhaled Notes to Physician General advice

Seek medical attention if feeling unwell. Show the SDS to the physician in attendance.

5. Fire-fighting Measures

Flammable properties Extinguishing media

Flammable.
Carbon dioxide, dry chemical, dry sand or limestone powder.

Protection of firefighters

Firefighters should wear protective clothing including self contained breathing apparatus.

Hazardous combustion products

May include and not limited to oxides of carbon. Ammonia gas may be liberated at high temperatures. May generate toxic nitrogen oxide gases. Burning produces noxious and toxic fumes. Downwind personnel should be evacuated.

Unusual Fire, Explosion hazards

Containers may melt or rupture from heat of fire.

Further information

Do not allow run off from fire fighting to enter drains or water ways. Fire residues and contaminated fire extinguishing water must be disposed of in accordance with local regulations.



AQ-280 Rust Inhibitor Safety Data Sheets

Medical Equipment Washing & Decontamination Systems



NATIONAL PURITY, LLC.
6840 SHINGLE CREED PKWY, STE 23
BROOKLYN CENTER, MN 55430
(612) 672-0022

6. Accidental Release Measures

Personal precautions	Keep unnecessary personal away. Do not touch or walk through spilled material. Do not touch damaged containers or spilled containers unless wearing protective Clothing.
Methods for containment	Prevent entry into waterways, sewers.
Methods for cleaning up	Before attempting clean up, refer to hazard data given above. Small spills may be mopped up placed in a container for disposal. Large spills: dike with suitable material and prevent discharge into waterways. Spill may be absorbed with non reactive material and placed in a suitable container for disposal. Residues can be rinsed with water and placed in suitable container for disposal. Dispose of contents/containers in accordance with local, state, and federal regulations.

7. Handling and Storage

Precautions for Safe Handling	Use good industrial hygiene practices when handling this material. Wash contaminated clothing before reuse.
Conditions for Safe Storage	Keep container closed when not in use. Keep away from heat or sources of ignition.. Store in cool dry place.

8. Exposure Controls and Personal Protection

Exposure Limits	CAS#	OSHA PEL	ACGIH TLV
Ingredients			
1-Propanamine, 3-(isodecyloxy)-,acetate	28701-67-9	Not available	Not available
Ethylene glycol monobutyl ether	111-76-2	Not available	Not available
Isopropyl alcohol	67-63-0	400 ppm TWA, 980 mg/m ³ PEL	Not available

Engineering controls	Provide exhaust ventilation adequate to ensure concentrations are kept below exposure limits.
Personal protective equipment	
Eye/Face protection	Wear goggles or safety glasses with side shields if splash conditions exist.
Hand protection	Wear rubber or neoprene safety gloves.
Skin and body	As required by employer code.
Respiratory protection	Use a NIOSH approved respirator when exposure guidelines are exceeded.
General hygiene considerations	Handle in accordance with good industrial hygiene practices. Do not eat or drink when using product. Wash hands well before breaks and immediately after handling the product.

9. Physical and Chemical Properties

Information on basic physical and chemical properties	
Appearance/form	Clear liquid
Color	Amber
Odor	Solvent/alcohol
Odor threshold	Not established
pH	6.2-6.6 (concentrate)
Melting/freezing point	Not established
Initial Boiling point	>212° F. (100° C.)
Flash point	130° F. (54° C.) Estimated.
Evaporation rate	Not established
Flammability	Flammable liquid and vapors
Upper/lower flammability or	Not established
Explosive limits	Not established

6/1/2015

Page 3 of 6



AQ-280 Rust Inhibitor

Safety Data Sheet

Medical Equipment Washing & Decontamination Systems



NATIONAL PURITY, LLC.
6840 SHINGLE CREED PKWY, STE 23
BROOKLYN CENTER, MN 55430
(612) 672-0022

Vapor pressure	Not established
Vapor density	Not established
Specific gravity/density	0.87-0.88
Vapor density	Not established
Solubility in water	Complete
VOC	< 20.0%
% Volatile	≈ 75%

Other Safety Information

10. Stability and Reactivity

Reactivity	
Chemical Stability	Stable under normal storage conditions.
Hazardous reactions	
Conditions to avoid	Do not mix with other chemicals.
Incompatible materials	Strong acids, strong oxidizing agents and amines.
Hazardous decomposition products	May include but not limited to oxides of carbon, phosphorous, and nitrogen. Nitric acid and ammonia.
Hazardous polymerization	Will not occur.

11. Toxicological Information

Ingredients	LC50
1-Propanamine, 3-(isodecyloxy)-,acetate	Not available.
Ethylene glycol monobutyl ether	Not available.
Isopropyl alcohol	16000 ppm (inhalation rat- 8 hours)
Ingredients	LD50
1-Propanamine, 3-(isodecyloxy)-,acetate	1,200 mg/kg (Oral-rat)
Ethylene glycol monobutyl ether	Not available.
Isopropyl alcohol	5,045 mg/kg (Oral-rat), 12,800 mg/kg (Dermal-rabbit)
Effects of acute exposure	
Eye	Will cause serious eye damage.
Skin	Will cause severe skin burns.
Ingestion	May be harmful if swallowed. May cause irritation to mouth, throat and stomach.
Inhalation	Risk of serious damage to the lungs.
Sensitization	Not known.
Chronic effects of short and long Term exposure	Prolonged exposure to skin may cause drying, defatting and irritation.
Carcinogenicity	Does not contain ingredients considered carcinogenic by NTP, IARC, or OSHA.
Mutagenicity	No data available.
Reproductive effects	No data available.
Teratogenicity	No data available.

12. Ecological Information

Eco-toxicity	Ecological effects for this product have not been analyzed.
Aquatic toxicity	
1-Propanamine, 3-(isodecyloxy)-, acetate	No data available
Ethylene glycol monbutyl ether	No data available.
Isopropyl alcohol	LC50 Fathead minnow: 9,640 mg/l 24 hours EC50 Daphnia magna (water flea) 5,102 mg/l 24 hours EC50 Algae : > 1000 mg/l 24 hours



AQ-280 Rust Inhibitor Safety Data Sheets

Medical Equipment Washing & Decontamination Systems

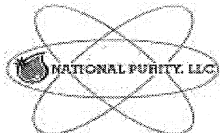

NATIONAL PURITY, LLC.
6840 SHINGLE CREED PKWY, STE 23
BROOKLYN CENTER, MN 55430
(612) 672-0022

Environmental effects	No data available.
Persistence and Degradability	No data available.
Bioaccumulation/accumulation	No data available.
Partition coefficient	No data available.
Mobility in environmental media	No data available.
Chemical fate information	No data available.
Other adverse effects	No data available.

13. Disposal Considerations

Waste codes	Not Available
Disposal instructions	Dispose in accordance with local, state, and federal regulations.
Wastes from residues/unused product	Containerize. Rinse area with water. Keep out of storm sewer/waterways.
Contaminated packaging	Dispose in accordance with all applicable regulations.

14. Transport Information

Basic shipping requirements:	
Proper shipping name	Flammable liquid, corrosive, n.o.s.(contains isopropyl alcohol, ethylene glycol monobutyl ether, 1-Propanamine, 3-[isodecyloxy]-, acetate), 3, UN2924, PG II
Hazard class	3
UN number	UN2924
Packing group	PG II
Packaging exceptions	None
Special provisions	

15. Regulatory Information

U.S federal regulations	This product has been classified in accordance with the Occupational Safety and Health Administration hazard criteria and the SDS contains all of the information required by OSHA. HCS 2012
TSCA	All ingredients are listed on the Toxic Substances Control Act.
Cercla SuperFund 40CFR117.302	This product does contain a material with a Reportable Quantity (RQ): Ethylene glycol monobutyl ether RQ = 5000 Lbs.
SARA Title III Section 311&312	Immediate (Acute) Health Hazard: 1-Propanamine, 3-(isodecyloxy)-,acetate CAS#28701-67-9 Ethylene glycol monobutyl ether CAS#111-76-2 Isopropyl alcohol CAS#67-63-0
SARA Title III Section 313	Product does contain substances on the list of Toxic Chemicals per 40CFR372: Ethylene glycol monobutyl ether CAS#111-76-2 Isopropyl alcohol CAS#67-63-0
CA Proposition 65	This product does contain chemicals known to the State of California to cause cancer, or reproductive effects: Trace amounts of Nickel.
States Right to Know	Reportable chemicals: Isopropyl alcohol



AQ-280 Rust Inhibitor Safety Data Sheets

Medical Equipment Washing & Decontamination Systems



NATIONAL PURITY, LLC.
6840 SHINGLE CREED PKWY, STE 23
BROOKLYN CENTER, MN 55430
(612) 672-0022

Inventory Status

Countries

U.S.
Canada

Inventory Name

CIL
DSL

On Inventory (Yes/No)*

Yes
Yes

- A "Yes" indicates that all of the components of this product comply with the inventory requirements administered by the governing country(s) listed.

16. Other Information

HMIS RATING

HMIS Legend

Severe 4
Serious 3
Moderate 2
Slight 1
Minimal 0

Health	3
Flammability	2
Reactivity	0
Personal Protection	B

Disclaimer

To the best of our knowledge, the information included herein is accurate. However, neither the above named supplier nor any of its subsidiaries assume any liability whatsoever for the accuracy or completeness of the information contained herein. Final determination of the suitability of any material is the responsibility of the user. All materials may present unknown hazards and should be used with caution. Although certain hazards are described herein, we cannot guarantee that these are the only hazards that exist.

Issue date

June 1, 2015

Supersedes date

Previous issues

Reason for update

Conform to GHS OSHA HCS 2012

Expiration date

June 1, 2018



AQ-725 De-Liming Solution Safety Data Sheets

Medical Equipment Washing & Decontamination Systems



NATIONAL PURITY, LLC.
6840 SHINGLE CREEK PKWY, STE 23
BROOKLYN CENTER, MN 55430
(612) 672-0022

SAFETY DATA SHEET

1. Product and Company Identification

Product Name	AQ-725 AQUAPHASE DE-LIMING SOLUTION
Product Number	515
Product Type	Mixture
Product Use	Descaling of mineral deposits on hard surfaces
Manufacturer/Supplier	National Purity, LLC. 6840 Shingle Creek Parkway, Suite #23 Brooklyn Center, MN 55430
Company Contact	612-672-0022
Emergency Telephone Number	1-800-255-3924

2. Hazards Identification

GHS Classification in accordance with 29 CFR 1910 OSHA HCS

Acute toxicity, Oral (Category 1) H300,
Acute toxicity, Inhalation (Category 4) H332
Skin corrosion/irritation, (Category 1) H314
Eye irritation, (Category 1) H318
Specific target organ toxicity (Category 1) H370
Chronic aquatic toxicity, (Category 1) H410

GHS Label elements, including precautionary statements

Pictogram



Signal word

Danger

Hazard Statements

H300 Fatal if swallowed. May cause corrosive damage to mouth, throat, or stomach.
H314 Causes severe skin burns and eye damage. Corrosive to the eyes leading to blindness
H332 Harmful if inhaled.
H370 Inhalation can cause irritation or corrosion to upper respiratory tract, including nose, mouth, and throat. Ingestion can cause corrosive burns to mouth, throat, and stomach.
H410 Very toxic to aquatic life with long lasting effects.

Precautionary Statements

Prevention

P280 Wear protective gloves/protective clothing/eye protection/face protection.
P264 Wash hands thoroughly after handling.
P270 Do not eat, drink or smoke when using this product.
P260 Do not breath fumes, mists, vapors or spray.
P284 In case of inadequate ventilation, use NIOSH approved respirator.
P273 Avoid release to the environment.

Response

P303+P361+P353+P363 IF ON SKIN (or hair), immediately take off all contaminated clothing and rinse skin with copious amounts of water. Shower if facilities are readily available.
Wash all contaminated clothing before reuse.
P310 Immediately call a POISON CENTER/doctor and seek medical attention.



AQ-725 De-Liming Solution Safety Data Sheets

Medical Equipment Washing & Decontamination Systems



NATIONAL PURITY, LLC.
6840 SHINGLE CREED PKWY, STE 23
BROOKLYN CENTER, MN 55430
(612) 672-0022

P301+P312+P330	IF SWALLOWED, immediately call a POISON CENTER/doctor. DO NOT INDUCE VOMITING. Rinse mouth with water.
P305+P351+P337+P310	IF IN EYES, rinse cautiously for several minutes. Remove contact lenses if present. Continue rinsing. Immediately call a POISON CENTER/doctor and get medical attention.
P304+P340+P312	IF INHALED: remove person to fresh air and keep comfortable for breathing. Call a POISON CENTER/doctor if feeling unwell.
P308+P311+P321	If exposed or concerned, call a POISON CENTER/doctor. See supplemental First Aid instructions in section 4.
Storage/Disposal	
P405	Store locked up.
P501	Dispose of contents/container in accordance with local/regional/federal regulations.

3. Composition/Information on Ingredients

The criteria for listing components in this section are: Ingredients that meet the criteria for carcinogenic, toxic to reproduction, or specific target organ toxicity and components otherwise considered hazardous according to OSHA which exceed the cut off limits for SDS specified by the criteria for mixtures are listed. Non hazardous components are not listed. This is not a composition disclosure. Exact percentages are considered proprietary and a trade secret.

Hazardous Components	CAS#	Classification	%
Phosphoric acid	7664-38-2	H300, H314, H318, H410	30-40%
Hydroxyacetic acid	79-14-1	H302, H314, H332	0-3%

4. First Aid Measures

Description of First Aid Procedures

General Advice	Consult a physician. Show this SDS to the doctor.
In Case of Eye Contact	Flush with cool running water for 15 minutes. Remove contact lenses if present. Get immediate medical attention.
In Case of Skin Contact	Wash with soap and water and rinse thoroughly with cool running water. Remove contaminated clothing. Get immediate medical attention.
If Ingested	Rinse mouth with water. Do not induce vomiting. Obtain immediate medical attention. Never give anything by mouth to an unconscious person.
If Inhaled	Move person to fresh air. Consult a physician if feeling unwell. Symptoms may be delayed.
Notes to Physician	Seek medical attention if feeling unwell. Show the SDS to the physician in attendance.
General advice	

5. Fire-fighting Measures

Flammable properties	Not flammable.
Extinguishing media	Use dry chemical, foam, carbon dioxide or water fog.
Protection of firefighters	Firefighters should wear protective clothing including self contained breathing apparatus.
Hazardous combustion products	May include and not limited to oxides of phosphorus, and carbon.
Unusual Fire, Explosion hazards	Containers may melt or rupture from heat of fire. May form combustible mixtures with air when heated.

6. Accidental Release Measures

Personal precautions	Keep unnecessary personal away. Do not touch or walk through spilled material. Do not touch damaged containers or spilled containers unless wearing protective clothing.
-----------------------------	--



AQ-725 De-Liming Solution Safety Data Sheets

Medical Equipment Washing & Decontamination Systems



NATIONAL PURITY, LLC.
6840 SHINGLE CREED PKWY, STE 23
BROOKLYN CENTER, MN 55430
(612) 672-0022

Methods for containment
Methods for cleaning up

Stop leak if you can do so without risk. Prevent entry into waterways, sewers. Before attempting clean up, refer to hazard data given above. Large spills, dike area to prevent from spreading. Neutralize with alkaline material such as soda ash or lime. Absorb with non reactive absorbent and place in suitable, covered, and labeled container. Rinse area with water. Never return spill to original container.

Environmental precautions

Avoid spills. Keep out of waterways.

7. Handling and Storage

Precautions for Safe Handling

Use good industrial hygiene practices when handling this material. Avoid contact with eyes, skin and clothing. Wash contaminated clothing before reuse.

Conditions for Safe Storage

Keep container closed when not in use. Store in cool well ventilated area. Keep away from heat. Store locked up.

8. Exposure Controls and Personal Protection

Exposure Limits

Ingredients

Phosphoric acid
Hydroxyacetic acid

CAS#

7664-38-2
79-14-1

OSHA PEL

Not available
Not available

ACGIH TLV

Not available
Not available

Engineering controls

Local exhaust ventilation is recommended. Ventilation system should be designed according to approved engineering standards.

Personal protective equipment

Eye/Face protection

Wear chemical safety goggles or full face shield if splash conditions exist. Have suitable eye wash water available. Shower near by.

Hand protection

Wear impermeable gloves to prevent contact with skin.

Skin and body

Wear impervious protective clothing including boots, gloves, and face shield where splashing is possible. Have quick drench/shower facilities in work area. Use a NIOSH approved respirator when exposure guidelines are exceeded.

Respiratory protection

General hygiene considerations

Handle in accordance with good industrial hygiene practices. Do not eat or drink when using product. Wash hands well before breaks and immediately after handling the product.

9. Physical and Chemical Properties

Information on basic physical and chemical properties

Appearance/form	Clear liquid
Color	Colorless
Odor	Odorless
Odor threshold	Not established
pH	1.7 (1% solution)
Melting/freezing point	Not established
Initial Boiling point	>212° F. (100° C.)
Flash point	Not established
Evaporation rate	Not established
Flammability	Not flammable
Upper/lower flammability or	Not applicable
Explosive limits	Not applicable
Vapor pressure	Not established
Vapor density	Not established
Specific gravity/density	Not established
Solubility in water	Complete



AQ-725 De-Liming Solution Safety Data Sheets

Medical Equipment Washing & Decontamination Systems



NATIONAL PURITY, LLC.
6840 SHINGLE CRED PKWY, STE 23
BROOKLYN CENTER, MN 55430
(612) 672-0022

VOC < 0.1%
% Volatile Approx. 60%
Other Safety Information

10. Stability and Reactivity

Reactivity	
Chemical Stability	Stable under normal conditions of storage, handling and use.
Hazardous reactions	Keep separate from organic materials. Avoid contact with alkaline materials and metals.
Conditions to avoid	High temperatures. Do not mix with other chemicals.
Incompatible materials	Strong alkalis, strong oxidizing agents, and reactive metals, such as aluminum, copper, brass,, bronze and mild steel.
Hazardous decomposition products	May include but not limited to oxides of carbon, phosphorous and phosphine from thermal decomposition. Hydrogen gas from reaction with metals.
Hazardous polymerization	Will not occur.

11. Toxicological Information

Ingredients	LC50
Phosphoric acid	1,689 mg/m ³ P ₂ O ₅
Hydroxyacetic acid	7.7 mg/L
Ingredients	LD50
Phosphoric acid	1,530 mg/kg (Oral-rat), > 1,260-3,160 mg/kg (Dermal-rabbit)
Hydroxyacetic acid	4240 mg/kg (oral-rat)
Eye	Causes severe eye damage. Corrosive to eyes leading to blindness
Skin	May cause severe skin burns.
Ingestion	Fatal if swallowed. May cause corrosive damage to mouth, throat and stomach.
Inhalation	Fatal if inhaled. Can cause pulmonary edema and chemical pneumonitis.
Sensitization	No data available.
Chronic effects of short and long Term exposure	Prolonged exposure to skin may cause drying, defatting and irritation and aggravate existing skin problems
Carcinogenicity	Does not contain ingredients considered carcinogenic by NTP, IARC, or OSHA.
Mutagenicity	No data available
Reproductive effects	No data available
Teratogenicity	No data available.

12. Ecological Information

Eco-toxicity	Ecological effects for this product have not been analyzed. However, if spilled this products ingredients are toxic to aquatic life and may have long lasting effects. EPA Ecological Toxicity rating: High.
Phosphoric acid	
Environmental effects	Phosphoric acid dissolves some soil materials (carbonates),
Aquatic toxicity	Dangerous to aquatic plants at high concentrations.
Phosphoric acid	
Persistence and Degradability	Under anaerobic conditions, microorganisms may degrade phosphoric acid to phosphine.
Bioaccumulation/accumulation	Inorganic phosphates have the potential to increase the growth of algae, whose eventual death will reduce the available oxygen for aquatic life.
Phosphoric acid	

5/9/2015

Page 4 of 6



AQ-725 De-Liming Solution Safety Data Sheets

Medical Equipment Washing & Decontamination Systems

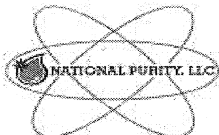

NATIONAL PURITY, LLC.
6840 SHINGLE CREED PKWY, STE 23
BROOKLYN CENTER, MN 55430
(612) 672-0022

Partition coefficient	Not Available
Mobility in environmental media	Not Available
Chemical fate information	Not Available
Other adverse effects	Not Available

13. Disposal Considerations

Waste codes	Not Available
Disposal instructions	Dispose in accordance with local, state, and federal regulations.
Wastes from residues/unused product	Containerize. Rinse area with water. Keep out of storm sewer/waterways.
Contaminated packaging	Dispose of container in accordance with federal, state, and local requirements.

14. Transport Information

Basic shipping requirements:	
Proper shipping name:	Corrosive liquids, acidic, inorganic, n.o.s. (contains phosphoric acid)
Hazard class	8
UN number	3264
Packing group	III
Special provisions	
Packaging exceptions	49CFR173.154 limited quantities

15. Regulatory Information

U.S federal regulations	This product has been classified in accordance with the Occupational Safety and Health Administration hazard criteria and the SDS contains all of the information required by OSHA. HCS 2012	
TSCA	All ingredients are listed on the Toxic Substances Control Act.	
CERCLA Super Fund 40CFR117.302	Product contains a material with a Reportable Quantity (RQ) Phosphoric acid RQ = 5000 Lbs.	
SARA Title III Section 311&312	Immediate (Acute) Health Hazard Phosphoric acid	
SARA Title III Section 313	No ingredients are subject to Section 313 Reporting Requirements. Sulfuric acid which may be present at levels < 2% is reportable.	
States Right to Know	Reportable chemicals: Sulfuric acid which may be present at trace amounts is reportable.	
Warning	This product contains a chemical known to the state of California to cause cancer, birth defects or reproductive effects: Sulfuric acid present at < 2%.	
Inventory Status	Inventory Name	On Inventory (Yes/No)*
Countries		
U.S.	CIL	Yes
Canada	DSL	Yes

- A "Yes" indicates that all of the components of this product comply with the inventory requirements administered by the governing country(s) listed.



AQ-725 De-Liming Solution Safety Data Sheets

Medical Equipment Washing & Decontamination Systems

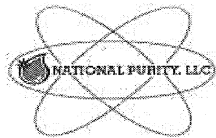

NATIONAL PURITY, LLC.
6840 SHINGLE CREED PKWY, STE 23
BROOKLYN CENTER, MN 55430
(612) 672-0022

16. Other Information

HMIS RATING

HMIS Legend

Severe	4
Serious	3
Moderate	2
Slight	1
Minimal	0

Health	3
Flammability	0
Reactivity	0
Personal Protection	B

Disclaimer

To the best of our knowledge, the information included herein is accurate. However, neither the above named supplier nor any of its subsidiaries assume any liability whatsoever for the accuracy or completeness of the information contained herein. Final determination of the suitability of any material is the responsibility of the user. All materials may present unknown hazards and should be used with caution. Although certain hazards are described herein, we cannot guarantee that these are the only hazards that exist.

Issue date

May 9, 2015

Supersedes date

Previous issues

Reason for update

Conform to GHS OSHA HCS 2012

Expiration date

May 9, 2018



DELIMING INSTRUCTIONS

Medical Equipment Washing & Decontamination Systems

WARNING: WEAR PERSONAL GEAR/ CLOTHING WHEN WORKING WITH ANY CHEMICALS.

Consult the Material Safety Data Sheets & your company's Hazardous Substance Policy before handling any chemicals.

Read all instructions before proceeding. The following detailed instructions are for "Deliming" your Aqua Phase Washer if it becomes necessary.

Call the factory with any questions regarding these instructions.

For your convenience, **AQ-725 Deliming Solution** may be ordered directly from **Aqua Phase** by calling 800-208-9274.

As with any cleaning operation using water, it is recommended that soft water be used.

Hard water contains a relatively high level of lime, calcium, and iron. Hard water will affect cleaning performance the same as it does your home laundry. After an extended period, the inside stainless steel walls of Aqua Phase may accumulate a white deposit.

If the build-up is extensive, we recommend the use of the **AQ-725 Deliming Solution**. A deliming solution purchased from a local hardware store such as "CLR" will help, but not as effective as the industrial grade Aqua Phase AQ-725 Deliming Solution.

We have specifically formulated the AQ-725 Deliming Solution to be used weekly, or as needed, to keep your Aqua Phase free from mineral build-up. The easy, ready-to-use quart bottles are pre-measured for the proper dilution rate for a single application. Packaged with 12 quarts per case, a routine schedule for deliming your Aqua Phase can be easily maintained.

DANGER: Causes eye and skin burns. Harmful if swallowed. Contains Hydroxyacetic and Phosphoric Acids.

FIRST AID: In case of eye contact, immediately flush with running water for at least 15 minutes and obtain medical aid. For skin contact, flush with running water. If swallowed, do not induce vomiting. Drink large amounts of water and call physician immediately.

**MIX ONLY WITH WATER - DO NOT USE ON ALUMINUM
FOR INDUSTRIAL USE ONLY | KEEP OUT OF THE REACH OF CHILDREN.**

*****Continued on next page*****



Medical Equipment Washing & Decontamination Systems

DELIMING INSTRUCTIONS (continued)

DO NOT CLIMB INTO THE WASH CHAMBER.

1. Carefully read and follow the notices and instruction labels of the de-liming solution you will be using.
2. Drain Aqua Phase.
3. Remove the Rinse and Detergent hoses from the cleaning solution bottles inside the Mechanical Cabinet at the rear of the machine.
4. Set the 'RUN/DRAIN' switch to "RUN".
5. Set the mode switch to "CLEAN".
6. Set the wash cycle time to "7 minutes" or the longest time cycle available.
7. Press the "START" button and allow Aqua Phase to fill.
8. As soon as Aqua Phase starts to spray water, press the "STOP" button.
 - At this point, the Aqua Phase water reservoir will be full. The Aqua Phase reservoir holds 5.5 gallons of water.
9. Open the front door and pour the proper amount of deliming solution directly into the water that is in the reservoir of the machine.
 - **BE CERTAIN** to add the proper amount of deliming solution according to the dilution rate recommended by the manufacturer of the deliming solution concentrate you are using (the *Aqua Phase* reservoir holds 5.5 gallons of water).
10. Close the front door and press the "START" button.
 - *Allow Aqua Phase to run for no longer than 4 minutes.*
 - Press the "STOP" button.
11. Wait approximately 5 minutes.
 - Set the wash cycle time to "7 minutes" or to the longest time cycle available.
 - Press the "START" button, and allow *Aqua Phase* to run a complete cycle.

Continued on next page



DELIMING INSTRUCTIONS (continued)

Medical Equipment Washing & Decontamination Systems

12. Press the “**START**” button and allow Aqua Phase to run another complete cycle.
13. Examine and clean the Reservoir Filter Screens.
 - Repeat steps 10 – 13 until the filter(s) collect minimal debris.
 - You may select “**3 minutes**” or the shortest time cycle available when repeating Steps 10 – 13.
14. Examine and clean the reservoir filter located inside the wash chamber reservoir.
15. Drain Aqua Phase.
16. Disconnect Aqua Phase from power source.
17. Shut-off the water supply to Aqua Phase.

Other Items:

Aqua Phase may not stop draining during Step 11 above.

The deliming solution will normally create foam inside the Wash Chamber. The foam may affect certain sensors that control the filling and draining of water.

In Step 11 above, if Aqua Phase does **not** stop draining after a few minutes, perform the following:

- a) Press the “**STOP**” button and wait a few minutes until the foam dissipates.
- b) Press the “**START**” button and allow Aqua Phase to do a complete cycle.
- c) Repeat the preceding Steps a) and b) until Aqua Phase starts draining normally.
- d) Return to Step 11 above.

CHECK FOR DEBRIS IN THE SPRAY NOZZLES.

If your unit does not have the reservoir filter screens seated properly in their place at all times, you can expect most of the spray nozzles to become clogged during the deliming of your machine. After you have completed the deliming processes above, check the spray nozzles to make certain they are not clogged.



HDQ 1202 Neutral Disinfectant Safety Data Sheets

Medical Equipment Washing & Decontamination Systems



Safety Data Sheet Spartan Chemical Company, Inc.

Revision Date: 28-Apr-2015

1. PRODUCT AND COMPANY IDENTIFICATION

Product Identifier

Product Name: HDQ NEUTRAL
Product Number: 1202
Recommended Use: Disinfectant
Uses Advised Against: For Industrial and Institutional Use Only

Manufacturer/Supplier: Spartan Chemical Company, Inc.
 1110 Spartan Drive
 Maumee, Ohio 43537 USA
 800-537-8990 (Business hours)
www.spartanchemical.com

24 Hour Emergency Phone Numbers:

Medical Emergency/Information: 888-314-6171
Transportation/Spill/Leak: CHEMTREC 800-424-9300

2. HAZARDS IDENTIFICATION

GHS Classification

Acute Toxicity - Oral: Category 4
Skin Corrosion/Irritation: Category 1 Sub-category B
Serious Eye Damage/Eye Irritation: Category 1

GHS Label Elements

Signal Word:
Symbols:

Danger

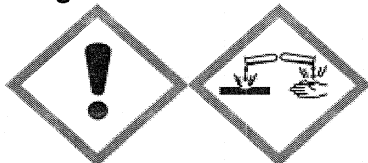

Hazard Statements:

Harmful if swallowed.
 Causes severe skin burns and serious eye damage.

Precautionary Statements:

Prevention:

Wash hands and any exposed skin thoroughly after handling.
 Do not eat, drink or smoke when using this product
 Do not breathe mist, vapors or spray.
 Wear protective gloves. Wear eye / face protection. Wear protective clothing.

Response:

-Eyes

IMMEDIATELY CALL A POISON CENTER OR PHYSICIAN.
 IF IN EYES: Rinse cautiously with water for several minutes. Remove contact lenses, if present and easy to do. Continue rinsing.

-Skin

IF ON SKIN (or hair): Take off immediately all contaminated clothing. Rinse skin with water or shower. Wash contaminated clothing before reuse.

-Inhalation:

IF INHALED: Remove victim to fresh air and keep at rest in a position comfortable for breathing.

-Ingestion:

IF SWALLOWED: Rinse mouth. Do NOT induce vomiting.

-Specific Treatment:

See Safety Data Sheet Section 4: "FIRST AID MEASURES" for additional information.

Storage:

Store locked up.

Disposal:

Dispose of contents and container in accordance with local, state and federal regulations.



HDQ 1202 Neutral Disinfectant Safety Data Sheets

Medical Equipment Washing & Decontamination Systems

1202 - HDQ NEUTRAL

Revision Date: 28-Apr-2015

Hazards Not Otherwise Classified: Not Applicable

Other Information:

- Corrosive.
- Inhalation of vapors or mist may cause respiratory irritation.
- Keep out of reach of children.
- NOTE TO PHYSICIAN: Probable mucosal damage may contraindicate the use of gastric lavage.

0.32918% of the mixture consists of ingredient(s) of unknown toxicity.

3. COMPOSITION/INFORMATION ON INGREDIENTS

Chemical Name	CAS No	Weight-%
water	7732-18-5	60-100
didecyltrimethylammonium chloride	7173-51-5	3-7
alkyl dimethyl benzyl ammonium chloride	68424-85-1	1-5
ethanol	64-17-5	1-5
tetrasodium ethylenediaminetetraacetate	64-02-8	1-5
alcohol ethoxylate	68439-46-3	1-5

Specific chemical identity and/or exact percentage of composition has been withheld as a trade secret.

4. FIRST AID MEASURES

- Eye Contact:** Rinse cautiously with water for at least 15 minutes. Remove contact lenses, if present and easy to do. Continue rinsing. IMMEDIATELY CALL A POISON CENTER OR PHYSICIAN.
- Skin Contact:** Take off immediately all contaminated clothing and shoes. Rinse with water or shower for at least 15 minutes. IMMEDIATELY CALL A POISON CENTER OR PHYSICIAN. Wash contaminated clothing before reuse.
- Inhalation:** Remove victim to fresh air and keep at rest in a position comfortable for breathing. IMMEDIATELY CALL A POISON CENTER OR PHYSICIAN.
- Ingestion:** Rinse mouth. Do NOT induce vomiting. IMMEDIATELY CALL A POISON CENTER OR PHYSICIAN. Never give anything by mouth to an unconscious person.
- Note to Physicians:** NOTE TO PHYSICIAN: Probable mucosal damage may contraindicate the use of gastric lavage.

5. FIRE-FIGHTING MEASURES

- Suitable Extinguishing Media:** Product does not support combustion, Use extinguishing agent suitable for type of surrounding fire
- Specific Hazards Arising from the Chemical:** Dried product is capable of burning. Combustion products are toxic.
- Hazardous Combustion Products:** May include Carbon monoxide Carbon dioxide and other toxic gases or vapors.
- Protective Equipment and Precautions for Firefighters:** Wear MSHA/NIOSH approved self-contained breathing apparatus (SCBA) and full protective gear. Cool fire-exposed containers with water spray.

6. ACCIDENTAL RELEASE MEASURES

- Personal Precautions:** Avoid contact with skin, eyes or clothing. Use personal protective equipment as required.
- Environmental Precautions:** Do not rinse spill onto the ground, into storm sewers or bodies of water.
- Methods for Clean-Up:** Prevent further leakage or spillage if safe to do so. Contain and collect spillage with non-combustible absorbent material, (e.g. sand, earth, diatomaceous earth, vermiculite) and place in container for disposal according to local / national regulations (see Section 13).

7. HANDLING AND STORAGE



HDQ 1202 Neutral Disinfectant Safety Data Sheets

Medical Equipment Washing & Decontamination Systems

1202 - HDQ NEUTRAL

Revision Date: 28-Apr-2015

Advice on Safe Handling: Handle in accordance with good industrial hygiene and safety practice. Wash thoroughly after handling.

Storage Conditions: Keep containers tightly closed in a dry, cool and well-ventilated place. Keep out of the reach of children. Keep from freezing.

8. EXPOSURE CONTROLS/PERSONAL PROTECTION

Occupational Exposure Limits:

Chemical Name	ACGIH TLV	OSHA PEL	NIOSH
ethanol 64-17-5	STEL: 1000 ppm	TWA: 1000 ppm TWA: 1900 mg/m ³ (vacated) TWA: 1000 ppm (vacated) TWA: 1900 mg/m ³	IDLH: 3300 ppm TWA: 1000 ppm TWA: 1900 mg/m ³

Engineering Controls: Provide good general ventilation. If work practices generate dust, fumes, gas, vapors or mists which expose workers to chemicals above the occupational exposure limits, local exhaust ventilation or other engineering controls should be considered. Eye wash stations and shower facilities should be readily accessible in areas where the product is handled.

Personal Protective Equipment

Eye/Face Protection: Wear splash goggles.

Skin and Body Protection: Wear rubber or other chemical-resistant gloves.

Respiratory Protection: Not required with expected use. If occupational exposure limits are exceeded or respiratory irritation occurs, use of a NIOSH/MSHA approved respirator suitable for the use-conditions and chemicals in Section 3 should be considered.

General Hygiene Considerations: Wash hands and any exposed skin thoroughly after handling. See 29 CFR 1910.132-138 for further guidance.

9. PHYSICAL AND CHEMICAL PROPERTIES

Appearance/Physical State:	Liquid
Color:	Red
Odor:	Mild Citrus fragrance
pH:	7.2-8.2
Melting Point / Freezing Point:	No information available.
Boiling Point / Boiling Range:	100 °C / 212 °F
Flash Point:	> 100 °C / > 212 °F
Evaporation Rate:	< 1 (Butyl acetate = 1)
Flammability (solid, gas)	No information available.
Upper Flammability Limit:	No information available.
Lower Flammability Limit:	No information available.
Vapor Pressure:	No information available.
Vapor Density:	No information available.
Specific Gravity:	1.00
Solubility(ies):	Soluble in water
Partition Coefficient:	No information available.
Autoignition Temperature:	No information available.
Decomposition Temperature:	No information available.
Viscosity:	No information available.

10. STABILITY AND REACTIVITY

Reactivity: This material is considered to be non-reactive under normal conditions of use.

Chemical Stability: Stable under normal conditions.

Possibility of Hazardous Reactions: Not expected to occur with normal handling and storage.

Conditions to Avoid: Extremes of temperature and direct sunlight.



HDQ 1202 Neutral Disinfectant Safety Data Sheets

Medical Equipment Washing & Decontamination Systems

1202 - HDQ NEUTRAL

Revision Date: 28-Apr-2015

Incompatible Materials: Strong oxidizing agents. Strong acids.
Hazardous Decomposition Products: May include carbon monoxide, carbon dioxide (CO₂) and other toxic gases or vapors.

11. TOXICOLOGICAL INFORMATION

Likely Routes of Exposure: Eyes, Skin, Ingestion, Inhalation.
Symptoms of Exposure:
-Eye Contact: Pain, redness, swelling of the conjunctiva and tissue damage. Eye contact may cause permanent damage.
-Skin Contact: Pain, redness, blistering and possible chemical burn.
-Inhalation: Nasal discomfort and coughing. Irritation or damage to the mucus membranes of the respiratory tract.
-Ingestion: Damage or chemical burns to mouth, throat and stomach. Pain, nausea, vomiting and diarrhea.
Immediate, Delayed, Chronic Effects
Product Information: Data not available or insufficient for classification.
Chronic Toxicity: May cause adverse effects on the bone marrow and blood-forming system. May cause adverse liver effects. Contains a known or suspected reproductive toxin.
Target Organ Effects: Blood. Central nervous system. -Eyes. Liver. Reproductive System. Respiratory System. -Skin.

Numerical Measures of Toxicity

The following acute toxicity estimates (ATE) are calculated based on the GHS document.

ATEmix (oral): 1016 mg/kg
 ATEmix (dermal): 7198 mg/kg
 ATEmix (inhalation-dust/mist): 5.9 mg/l

Component Acute Toxicity Information

Chemical Name	Oral LD50	Dermal LD50	Inhalation LC50
water 7732-18-5	> 90 mL/kg (Rat)	Not Available	Not Available
didecyldimethylammonium chloride 7173-51-5	= 84 mg/kg (Rat)	Not Available	Not Available
alkyl dimethyl benzyl ammonium chloride 68424-85-1	= 426 mg/kg (Rat)	Not Available	Not Available
ethanol 64-17-5	= 7060 mg/kg (Rat)	Not Available	= 124.7 mg/L (Rat) 4 h
tetrasodium ethylenediaminetetraacetate 64-02-8	= 10 g/kg (Rat)	Not Available	Not Available
alcohol ethoxylate 68439-46-3	= 1378 mg/kg (Rat)	> 2 g/kg (Rabbit)	Not Available

Carcinogenicity: No components present at 0.1% or greater are listed as to being carcinogens by ACGIH, IARC, NTP or OSHA.

12. ECOLOGICAL INFORMATION

Ecotoxicity

Chemical Name	Algae/Aquatic Plants	Fish	Toxicity to Microorganisms	Crustacea
ethanol 64-17-5	Not Available	12.0 - 16.0: 96 h Oncorhynchus mykiss mL/L LC50 static 100: 96 h Pimephales promelas mg/L LC50 static 13400 - 15100: 96 h Pimephales promelas mg/L LC50 flow-through	Not Available	9268 - 14221: 48 h Daphnia magna mg/L LC50 10800: 24 h Daphnia magna mg/L EC50 2: 48 h Daphnia magna mg/L EC50 Static
tetrasodium ethylenediaminetetraacetate 64-02-8	1.01: 72 h Desmodesmus subspicatus mg/L EC50	41: 96 h Lepomis macrochirus mg/L LC50 static 59.8: 96 h Pimephales promelas mg/L LC50 static	Not Available	610: 24 h Daphnia magna mg/L EC50



HDQ Neutral Disinfectant Safety Data Sheets

Medical Equipment Washing & Decontamination Systems

1202 - HDQ NEUTRAL

Revision Date: 28-Apr-2015

Persistence and Degradability: No information available.
Bioaccumulation: No information available.

Other Adverse Effects: No information available.

13. DISPOSAL CONSIDERATIONS

Disposal of Wastes: Dispose of in accordance with federal, state and local regulations.
Contaminated Packaging: Dispose of in accordance with federal, state and local regulations.

14. TRANSPORT INFORMATION

DOT:
UN/ID No: UN1903
Proper Shipping Name: Disinfectants, liquid corrosive, n.o.s., (contains didecyl dimethyl ammonium chloride, n-alkyl dimethyl benzyl ammonium chloride)
Hazard Class: 8
Packing Group: III
Special Provisions: Shipping descriptions may vary based on mode of transport, quantities, package size, and/or origin and destination. Check with a trained hazardous materials transportation expert for information specific to your situation.

15. REGULATORY INFORMATION

TSCA Status: (Toxic Substance Control Act Section 8(b) Inventory)
All chemical substances in this product are included on or exempted from listing on the TSCA Inventory of Chemical Substances.

SARA 313
This product does not contain listed substances above the "de minimus" level

SARA 311/312 Hazard Categories

Acute Health Hazard:	Yes
Chronic Health Hazard:	No
Fire Hazard:	No
Sudden release of pressure hazard:	No
Reactive Hazard:	No

California Proposition 65

This product contains the following Proposition 65 chemicals

Chemical Name	California Proposition 65
ethanol - 64-17-5	Carcinogen
acetaldehyde - 75-07-0	Developmental Carcinogen

WARNING: This product contains a chemical known to the State of California to cause cancer.

WARNING: This product contains a chemical known to the State of California to cause cancer and birth defects or other reproductive harm.

EPA Pesticide Registration Number: 10324-155-5741

EPA Statement:

This chemical is a pesticide product registered by the Environmental Protection Agency and is subject to certain labeling requirements under federal pesticide law. These requirements differ from the classification criteria and hazard information required for safety data sheets, and for workplace labels of non-pesticide chemicals. Following is the hazard information as required on the pesticide label:

EPA Pesticide Label:

Danger. Keep out of reach of children. Corrosive. Causes irreversible eye damage and skin burns. Harmful if swallowed, inhaled or absorbed through the skin. Avoid breathing spray mist. Do not get in eyes, on skin, or on clothing. Wear goggles or face shield, rubber gloves and protective clothing when handling. Wash thoroughly with soap and water after handling and before eating, drinking, chewing gum, using tobacco or using the toilet. Remove contaminated clothing and wash clothing before reuse.

16. OTHER INFORMATION



HDQ Neutral Disinfectant Safety Data Sheets

Medical Equipment Washing & Decontamination Systems

1202 - HDQ NEUTRAL

Revision Date: 28-Apr-2015

NFPA
HMIS

Health Hazards: 3
Health Hazards: 3

Flammability: 0
Flammability: 0

Instability: 0
Physical Hazards: 0

Special: N/A

Revision Date:
Reasons for Revision:

28-Apr-2015
No information available.

Disclaimer:

The information provided in this Material Safety Data Sheet is correct to the best of our knowledge, information and belief at the date of its publication. The information given is designed only as a guidance for safe handling, use, processing, storage, transportation, disposal and release and is not to be considered a warranty or quality specification. The information relates only to the specific material designated and may not be valid for such material used in combination with any other materials or in any process, unless specified in the text.

End of Safety Data Sheet



PD 128 Disinfectant Safety Data Sheets

Medical Equipment Washing & Decontamination Systems



Safety Data Sheet Spartan Chemical Company, Inc.

Revision Date: 28-Apr-2015

1. PRODUCT AND COMPANY IDENTIFICATION

Product Identifier

Product Name: PD-128
Product Number: 1016
Recommended Use: Disinfectant
Uses Advised Against: For Industrial and Institutional Use Only

Manufacturer/Supplier: Spartan Chemical Company, Inc.
 1110 Spartan Drive
 Maumee, Ohio 43537 USA
 800-537-8990 (Business hours)
www.spartanchemical.com

24 Hour Emergency Phone Numbers:
Medical Emergency/Information: 888-314-6171
Transportation/Spill/Leak: CHEMTREC 800-424-9300

2. HAZARDS IDENTIFICATION

GHS Classification

Acute toxicity - Inhalation (Dusts/Mists) Category 4
 Skin Corrosion/Irritation: Category 1 Sub-category B
 Serious Eye Damage/Eye Irritation: Category 1

GHS Label Elements

Signal Word:

Symbols:

Danger

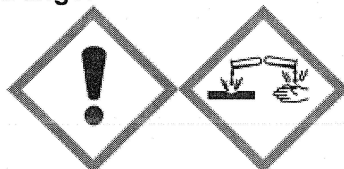

Hazard Statements:

Harmful if inhaled.
 Causes severe skin burns and serious eye damage.

Precautionary Statements:

Prevention:

Use only outdoors or in a well-ventilated area.
 Do not breathe mist, vapors or spray.
 Wash hands and any exposed skin thoroughly after handling.
 Wear protective gloves. Wear eye / face protection. Wear protective clothing.

Response:

-Eyes

IMMEDIATELY CALL A POISON CENTER OR PHYSICIAN.

IF IN EYES: Rinse cautiously with water for several minutes. Remove contact lenses, if present and easy to do. Continue rinsing.

-Skin

IF ON SKIN (or hair): Take off immediately all contaminated clothing. Rinse skin with water or shower. Wash contaminated clothing before reuse.

-Inhalation:

IF INHALED: Remove victim to fresh air and keep at rest in a position comfortable for breathing.

-Ingestion:

IF SWALLOWED: Rinse mouth. Do NOT induce vomiting.

-Specific Treatment:

See Safety Data Sheet Section 4: "FIRST AID MEASURES" for additional information.

Storage:

Store locked up.

Disposal:

Dispose of contents and container in accordance with local, state and federal regulations.



PD 128 Disinfectant Safety Data Sheets

Medical Equipment Washing & Decontamination Systems

1016 - PD-128

Revision Date: 28-Apr-2015

Hazards Not Otherwise Classified: Not Applicable

Other Information:

- Corrosive.
- Harmful if swallowed
- Keep out of reach of children.

0.27369% of the mixture consists of ingredient(s) of unknown toxicity.

3. COMPOSITION/INFORMATION ON INGREDIENTS

Chemical Name	CAS No	Weight-%
water	7732-18-5	60-100
o-benzyl-p-chlorophenol	120-32-1	1-5
o-phenylphenol	90-43-7	1-5
ethylene glycol	107-21-1	1-5
sodium hydroxide	1310-73-2	1-5
sodium lauryl sulfate	151-21-3	1-5
isopropanol	67-63-0	1-5

Specific chemical identity and/or exact percentage of composition has been withheld as a trade secret.

4. FIRST AID MEASURES

-Eye Contact: Rinse cautiously with water for at least 15 minutes. Remove contact lenses, if present and easy to do. Continue rinsing. IMMEDIATELY CALL A POISON CENTER OR PHYSICIAN.

-Skin Contact: Take off immediately all contaminated clothing and shoes. Rinse with water or shower for at least 15 minutes. IMMEDIATELY CALL A POISON CENTER OR PHYSICIAN. Wash contaminated clothing before reuse.

-Inhalation: Remove victim to fresh air and keep at rest in a position comfortable for breathing. IMMEDIATELY CALL A POISON CENTER OR PHYSICIAN.

-Ingestion: Rinse mouth. Do NOT induce vomiting. IMMEDIATELY CALL A POISON CENTER OR PHYSICIAN. Never give anything by mouth to an unconscious person.

Note to Physicians: NOTE TO PHYSICIAN: Probable mucosal damage may contraindicate the use of gastric lavage. Measures against circulatory shock, respiratory depression and convulsion may be needed.

5. FIRE-FIGHTING MEASURES

Suitable Extinguishing Media: Product does not support combustion, Use extinguishing agent suitable for type of surrounding fire

Specific Hazards Arising from the Chemical: Dried product is capable of burning. Combustion products are toxic.

Hazardous Combustion Products: May include Carbon monoxide Carbon dioxide and other toxic gases or vapors.

Protective Equipment and Precautions for Firefighters: Wear MSHA/NIOSH approved self-contained breathing apparatus (SCBA) and full protective gear. Cool fire-exposed containers with water spray.

6. ACCIDENTAL RELEASE MEASURES

Personal Precautions: Avoid contact with skin, eyes or clothing. Use personal protective equipment as required.

Environmental Precautions: Do not rinse spill onto the ground, into storm sewers or bodies of water.

Methods for Clean-Up: Prevent further leakage or spillage if safe to do so. Contain and collect spillage with non-combustible absorbent material, (e.g. sand, earth, diatomaceous earth, vermiculite) and place in container for disposal according to local / national regulations (see Section 13).

7. HANDLING AND STORAGE



PD 128 Disinfectant Safety Data Sheets

Medical Equipment Washing & Decontamination Systems

1016 - PD-128

Revision Date: 28-Apr-2015

Advice on Safe Handling: Handle in accordance with good industrial hygiene and safety practice. Wash thoroughly after handling.

Storage Conditions: Keep containers tightly closed in a dry, cool and well-ventilated place. Keep out of the reach of children. Keep from freezing.

8. EXPOSURE CONTROLS/PERSONAL PROTECTION

Occupational Exposure Limits:

Chemical Name	ACGIH TLV	OSHA PEL	NIOSH
ethylene glycol 107-21-1	Ceiling: 100 mg/m ³ aerosol only	(vacated) Ceiling: 50 ppm (vacated) Ceiling: 125 mg/m ³	-
sodium hydroxide 1310-73-2	Ceiling: 2 mg/m ³	TWA: 2 mg/m ³ (vacated) Ceiling: 2 mg/m ³	IDLH: 10 mg/m ³ Ceiling: 2 mg/m ³
isopropanol 67-63-0	STEL: 400 ppm TWA: 200 ppm	TWA: 400 ppm TWA: 980 mg/m ³ (vacated) TWA: 400 ppm (vacated) TWA: 980 mg/m ³ (vacated) STEL: 500 ppm (vacated) STEL: 1225 mg/m ³	IDLH: 2000 ppm TWA: 400 ppm TWA: 980 mg/m ³ STEL: 500 ppm STEL: 1225 mg/m ³

Engineering Controls: Provide good general ventilation. If work practices generate dust, fumes, gas, vapors or mists which expose workers to chemicals above the occupational exposure limits, local exhaust ventilation or other engineering controls should be considered. Eye wash stations and shower facilities should be readily accessible in areas where the product is handled.

Personal Protective Equipment

Eye/Face Protection: Wear splash goggles.

Skin and Body Protection: Wear rubber or other chemical-resistant gloves. (such as barrier laminate or butyl rubber, nitrile rubber, neoprene rubber, polyvinyl chloride, or viton with thickness of ≥ 14 mils). Applicators and other handlers must wear coveralls over long-sleeved shirt and long pants, socks and chemical-resistant footwear.

Respiratory Protection: Not required with expected use. If occupational exposure limits are exceeded or respiratory irritation occurs, use of a NIOSH/MSHA approved respirator suitable for the use-conditions and chemicals in Section 3 should be considered.

General Hygiene Considerations: Wash hands and any exposed skin thoroughly after handling. See 29 CFR 1910.132-138 for further guidance.



PD 128 Disinfectant Safety Data Sheets

Medical Equipment Washing & Decontamination Systems

1016 - PD-128

Revision Date: 28-Apr-2015

9. PHYSICAL AND CHEMICAL PROPERTIES

Appearance/Physical State:	Liquid
Color:	Amber
Odor:	Pleasant Floral fragrance
pH:	12.0-13.5
Melting Point / Freezing Point:	No information available.
Boiling Point / Boiling Range:	100 °C / 212 °F
Flash Point:	> 100 °C / > 212 °F ASTM D56
Evaporation Rate:	< 1 (Butyl acetate = 1)
Flammability (solid, gas)	No information available.
Upper Flammability Limit:	No information available.
Lower Flammability Limit:	No information available.
Vapor Pressure:	No information available.
Vapor Density:	No information available.
Specific Gravity:	1.05
Solubility(ies):	Soluble in water
Partition Coefficient:	No information available.
Autoignition Temperature:	No information available.
Decomposition Temperature:	No information available.
Viscosity:	No information available.

10. STABILITY AND REACTIVITY

Reactivity:	This material is considered to be non-reactive under normal conditions of use.
Chemical Stability:	Stable under normal conditions.
Possibility of Hazardous Reactions:	Not expected to occur with normal handling and storage.
Conditions to Avoid:	Extremes of temperature and direct sunlight.
Incompatible Materials:	Strong oxidizing agents. Strong acids.
Hazardous Decomposition Products:	May include carbon monoxide, carbon dioxide (CO ₂) and other toxic gases or vapors.

11. TOXICOLOGICAL INFORMATION

Likely Routes of Exposure:	Eyes, Skin, Ingestion, Inhalation.
Symptoms of Exposure:	
-Eye Contact:	Pain, redness, swelling of the conjunctiva and tissue damage. Eye contact may cause permanent damage.
-Skin Contact:	Pain, redness, blistering and possible chemical burn.
-Inhalation:	Nasal discomfort and coughing. Irritation or damage to the mucus membranes of the respiratory tract.
-Ingestion:	Pain, nausea, vomiting and diarrhea. Damage or chemical burns to mouth, throat and stomach.
Immediate, Delayed, Chronic Effects	
Product Information:	Data not available or insufficient for classification.
Target Organ Effects:	Central nervous system. -Eyes. Respiratory System. -Skin.
Numerical Measures of Toxicity	
The following acute toxicity estimates (ATE) are calculated based on the GHS document.	
ATEmix (oral):	4163 mg/kg
ATEmix (dermal):	12291 mg/kg
ATEmix (inhalation-dust/mist):	4.7 mg/l

Component Acute Toxicity Information

Chemical Name	Oral LD50	Dermal LD50	Inhalation LC50
water 7732-18-5	> 90 mL/kg (Rat)	Not Available	Not Available



PD 128 Disinfectant Safety Data Sheets

Medical Equipment Washing & Decontamination Systems

1016 - PD-128

Revision Date: 28-Apr-2015

o-phenylphenol 90-43-7	= 1049 mg/kg (Rat)	> 2000 mg/kg (Rat)	> 0.949 mg/L (Rat) 1 h
ethylene glycol 107-21-1	= 4000 mg/kg (Rat)	= 9530 µL/kg (Rabbit)	Not Available
sodium hydroxide 1310-73-2	Not Available	= 1350 mg/kg (Rabbit)	Not Available
sodium lauryl sulfate 151-21-3	= 1288 mg/kg (Rat)	= 580 mg/kg (Rabbit)	> 3900 mg/m ³ (Rat) 1 h
isopropanol 67-63-0	= 4396 mg/kg (Rat)	= 12800 mg/kg (Rat) = 12870 mg/kg (Rabbit)	= 72.6 mg/L (Rat) 4 h

Carcinogenicity: No components present at 0.1% or greater are listed as to being carcinogens by ACGIH, IARC, NTP or OSHA.

12. ECOLOGICAL INFORMATION

Ecotoxicity

Chemical Name	Algae/Aquatic Plants	Fish	Toxicity to Microorganisms	Crustacea
o-phenylphenol 90-43-7	0.85: 72 h <i>Desmodesmus subspicatus</i> mg/L EC50	3.4: 96 h <i>Pimephales promelas</i> mg/L LC50 flow-through 2.74: 96 h <i>Lepomis macrochirus</i> mg/L LC50 2.75: 96 h <i>Oncorhynchus mykiss</i> mg/L LC50 5.8: 96 h <i>Poecilia reticulata</i> mg/L LC50 static	Not Available	1 - 2.5: 48 h <i>Daphnia magna</i> mg/L EC50 Static
ethylene glycol 107-21-1	6500 - 13000: 96 h <i>Pseudokirchneriella subcapitata</i> mg/L EC50	41000: 96 h <i>Oncorhynchus mykiss</i> mg/L LC50 14 - 18: 96 h <i>Oncorhynchus mykiss</i> mL/L LC50 static 27540: 96 h <i>Lepomis macrochirus</i> mg/L LC50 static 40761: 96 h <i>Oncorhynchus mykiss</i> mg/L LC50 static 40000 - 60000: 96 h <i>Pimephales promelas</i> mg/L LC50 static 16000: 96 h <i>Poecilia reticulata</i> mg/L LC50 static	Not Available	46300: 48 h <i>Daphnia magna</i> mg/L EC50
sodium hydroxide 1310-73-2	Not Available	45.4: 96 h <i>Oncorhynchus mykiss</i> mg/L LC50 static	Not Available	Not Available



PD 128 Disinfectant Safety Data Sheets

Medical Equipment Washing & Decontamination Systems

1016 - PD-128

Revision Date: 28-Apr-2015

sodium lauryl sulfate 151-21-3	53: 72 h Desmodemus subspicatus mg/L EC50 30 - 100: 96 h Desmodemus subspicatus mg/L EC50 117: 96 h Pseudokirchneriella subcapitata mg/L EC50 3.59 - 15.6: 96 h Pseudokirchneriella subcapitata mg/L EC50 static	8 - 12.5: 96 h Pimephales promelas mg/L LC50 static 15 - 18.9: 96 h Pimephales promelas mg/L LC50 static 22.1 - 22.8: 96 h Pimephales promelas mg/L LC50 static 4.3 - 8.5: 96 h Oncorhynchus mykiss mg/L LC50 static 4.62: 96 h Oncorhynchus mykiss mg/L LC50 flow-through 4.2: 96 h Oncorhynchus mykiss mg/L LC50 7.97: 96 h Brachydanio rerio mg/L LC50 flow-through 9.9 - 20.1: 96 h Brachydanio rerio mg/L LC50 semi-static 4.06 - 5.75: 96 h Lepomis macrochirus mg/L LC50 static 4.2 - 4.8: 96 h Lepomis macrochirus mg/L LC50 flow-through 4.5: 96 h Lepomis macrochirus mg/L LC50 5.8 - 7.5: 96 h Pimephales promelas mg/L LC50 static 10.2 - 22.5: 96 h Pimephales promelas mg/L LC50 semi-static 6.2 - 9.6: 96 h Pimephales promelas mg/L LC50 13.5 - 18.3: 96 h Poecilia reticulata mg/L LC50 semi-static 10.8 - 16.6: 96 h Poecilia reticulata mg/L LC50 static 1.31: 96 h Cyprinus carpio mg/L LC50 semi-static	Not Available	1.8: 48 h Daphnia magna mg/L EC50
isopropanol 67-63-0	1000: 96 h Desmodemus subspicatus mg/L EC50 1000: 72 h Desmodemus subspicatus mg/L EC50	9640: 96 h Pimephales promelas mg/L LC50 flow-through 11130: 96 h Pimephales promelas mg/L LC50 static 1400000: 96 h Lepomis macrochirus µg/L LC50	Not Available	13299: 48 h Daphnia magna mg/L EC50

Persistence and Degradability: No information available.

Bioaccumulation: No information available.

Other Adverse Effects: No information available.

13. DISPOSAL CONSIDERATIONS

Disposal of Wastes: Dispose of in accordance with federal, state and local regulations.
Contaminated Packaging: Dispose of in accordance with federal, state and local regulations.

14. TRANSPORT INFORMATION

DOT:
UN/ID No: UN1760
Proper Shipping Name: Corrosive liquids, n.o.s., (contains sodium hydroxide)
Hazard Class: 8
Packing Group: II
Special Provisions: Shipping descriptions may vary based on mode of transport, quantities, package size, and/or origin and destination. Check with a trained hazardous materials transportation expert for information specific to your situation.



PD 128 Disinfectant Safety Data Sheets

Medical Equipment Washing & Decontamination Systems

1016 - PD-128

Revision Date: 28-Apr-2015

15. REGULATORY INFORMATION

TSCA Status: (Toxic Substance Control Act Section 8(b) Inventory)

All chemical substances in this product are included on or exempted from listing on the TSCA Inventory of Chemical Substances.

SARA 313

This product contains the following listed substances:

o-phenylphenol

CAS No 90-43-7

ethylene glycol

CAS No 107-21-1

isopropanol

CAS No 67-63-0 only if manufactured by the strong acid process, no supplier notification

SARA 311/312 Hazard Categories

Acute Health Hazard:	Yes
Chronic Health Hazard:	No
Fire Hazard:	No
Sudden release of pressure hazard:	No
Reactive Hazard:	No

California Proposition 65

This product contains the following Proposition 65 chemicals

Chemical Name	California Proposition 65
o-phenylphenol - 90-43-7	Carcinogen
sulfuric acid - 7664-93-9	Carcinogen
formaldehyde - 50-00-0	Carcinogen
methanol - 67-56-1	Developmental

WARNING: This product contains a chemical known to the State of California to cause cancer.

WARNING: This product contains a chemical known to the State of California to cause birth defects or other reproductive harm.

EPA Pesticide Registration Number: 39967-89-5741

EPA Statement:

This chemical is a pesticide product registered by the Environmental Protection Agency and is subject to certain labeling requirements under federal pesticide law. These requirements differ from the classification criteria and hazard information required for safety data sheets, and for workplace labels of non-pesticide chemicals. Following is the hazard information as required on the pesticide label:

EPA Pesticide Label:

Danger. Corrosive. Causes irreversible eye damage or skin burns. Harmful if swallowed or absorbed through skin. Do not get in eyes, on skin or clothing. Avoid breathing spray mist.

16. OTHER INFORMATION

NFPA Health Hazards: 3 Flammability: 1 Instability: 0 Special: N/A
HMIS Health Hazards: 3 Flammability: 1 Physical Hazards: 0

Revision Date: 28-Apr-2015
Reasons for Revision: No information available.

Disclaimer:

The information provided in this Material Safety Data Sheet is correct to the best of our knowledge, information and belief at the date of its publication. The information given is designed only as a guidance for safe handling, use, processing, storage, transportation, disposal and release and is not to be considered a warranty or quality specification. The information relates only to the specific material designated and may not be valid for such material used in combination with any other materials or in any process, unless specified in the text.

End of Safety Data Sheet



Medical Equipment Washing & Decontamination Systems

NOTES (Use this section for you own notes/reminders)

YOUR AQUA PHASE AQ-8000 BACKBOARD WASHER INFORMATION:

Model Number :

Serial Number:

Warranty Effective Dates:

Your Account Code:

If you have any technical questions regarding your Aqua Phase washer, please call 800-208-9274 for Technical Service Representative, at no charge to you.